

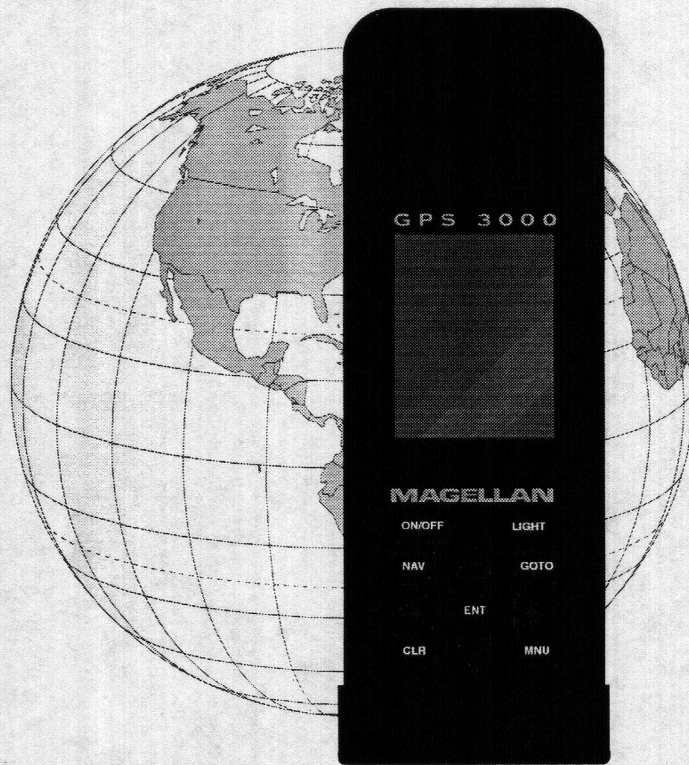

# Magellan GPS 3000 Satellite Navigator



## User Guide



**MAGELLAN**  
SYSTEMS CORPORATION

## GPS 3000 Field Reference Guide

### Battery Installation:

Install four AA alkaline batteries as shown.

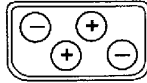

Bottom View

**NOTE: When instructed to:** Select ITEM

Highlight the menu item and press ENT.

### Turning the Receiver On:

**ON/OFF** Press and hold until COPYRIGHT is displayed

### Setting Contrast:

From any NAV Screen **ENT** Select CONTRAST

Adjust the CONTRAST **ENT**

### Viewing SAT STATUS Screen:

**MNU** Select SAT STATUS

### Saving Position as a Waypoint:

From any NAV Screen **ENT** Select SAVE POS

Choose one

Enter WPT Name **ENT**

**ENT** Receiver-generated name

### Creating a Waypoint:

From any NAV Screen **ENT** Select CREATE WPT

Enter WPT name, latitude, longitude, and elevation

### Viewing a Waypoint:

**MNU** Select WPT MENU Select Waypoint

### Clearing a Waypoint:

**MNU** Select WPT MENU Select Waypoint

**ENT** Select DELETE Confirm DELETE

### Activating a GOTO:

**GOTO** Select Waypoint

### Accessing the Route Menu:

**MNU** Select ROUTE MENU

- or -

From any NAV Screen **ENT** Select ROUTE MENU

### Creating a Route:

From Route Menu Select EMPTY Route\* Select "FROM" WPT

Select "TO" WPT Repeat for each leg (20 max) **ENT**

\* if no empty route, a route must be cleared.

### Reversing a Route:

From Route Menu Select Route **ENT** Select REVERSE

### Creating a Backtrack:

**GOTO** Select BCKTRK

### SETUP:

(Defaults in bold)

Coordinate System	<b>LAT/LON</b> UTM, TD, OSGB, Irish, Swiss, Swedish
Elevation Mode	<b>2D, 3D</b>
Time Display	<b>LOCAL AM/PM</b> LOCAL 24 HR UT
Speed Units	<b>KNOTS, MPH,</b> KPH
Distance Units	<b>NAUT MILES</b> ST MILES, KM
Elevation Units	<b>FEET, METERS</b>
North Reference	<b>MAG, TRUE</b>
Map Datum	<b>WGS84, Other...</b>
NMEA	<b>OFF, 0183A,B,C</b>
Baud Rate	<b>4800, Other...</b>
WPT Sort	<b>ALPHABETIC,</b> NEAREST
Plot Setup	<b>Track Up</b> 0.5 DIST



**MAGELLAN**  
SYSTEMS CORPORATION

960 Overland Ct., San Dimas, CA 91773  
(909) 394-5000

22-10205-000



## WARNINGS

A measure of knowledge by the user is required for proper and safe use of the **Magellan GPS 2000™**. READ THE USER GUIDE AND WARRANTY COMPLETELY.

### Use Good Judgement

This product is an excellent navigation aid, but it does not replace the need for careful orienteering and good judgement. Never rely solely on one device for navigating.

### Use Care to Avoid Inaccuracies

The Global Position System (GPS) is operated by the U.S. Government, which is solely responsible for the accuracy and the maintenance of GPS. Certain conditions can make the system less accurate.

Accuracy can also be affected by poor satellite geometry. WHEN THE ACCURACY WARNING APPEARS ON THE SCREEN, USE THIS DATA WITH EXTREME CAUTION.

THE GLOBAL POSITION SYSTEM IS A DoD SYSTEM. The government can make changes to the system that could affect the performance of GPS receivers.



### WARNING

The accuracy of position fixes can be affected by the periodic adjustments to GPS satellites by the U.S. Government and is subject to changes in accordance with the Department of Defense Civil GPS user policy and the Federal Radionavigation Plan.





## CONTENTS

### *Introduction*

Welcome to the GPS 3000 .....	1
Packing List.....	1
Conventions Used in this Manual.....	2
Commonly Used Terms .....	2

### *Getting Started*

GPS 3000 Description .....	4
Installing the Batteries .....	5
First Time Use — Initializing the Receiver .....	5
Getting Signals from Satellites .....	7
Taking a Position Fix .....	8
Saving Your Position as a Waypoint .....	9
Creating a New Waypoint .....	9
Creating a GOTO .....	10
Navigating with the GPS 3000 .....	10

### *Reference*

Powering the GPS 3000 .....	11
Turning the Receiver On/Off .....	11
Turning the Display Light On/Off .....	12
Contrast .....	12
Waypoints .....	13
Saving a Position as a Waypoint .....	13
Creating a Waypoint.....	13
Editing a Waypoint .....	14
Projecting a Waypoint.....	16
Viewing a Stored Waypoint .....	17
Deleting a Waypoint .....	17
Last Fix Buffer .....	18
Copying a Last Fix as a Waypoint .....	19
Deleting a Last Fix .....	19
GOTO .....	20
Activating a GOTO .....	20



MOB/ROUTE/BACKTRACK .....	20
NAV .....	21
Viewing the NAV Screens .....	21
POSITION Screen .....	22
SUN/MOON .....	22
NAV 1 Screen .....	23
NAV 2 Screen .....	24
POINTER Screen .....	25
PLOTTER Screen .....	26
PAN N SCAN .....	26
DELETE TRACK .....	27
ROAD Screen .....	28
ROUTES .....	28
Accessing the Route Menu .....	28
Creating a Route .....	29
Deactivating a Route .....	31
Activating a Route .....	31
Reversing a Route .....	31
Editing a Route .....	32
Inserting a waypoint from the leg edit menu .....	33
Deleting a leg using the leg edit menu .....	33
Replacing a waypoint in a route .....	34
Activating a leg of a route .....	34
Viewing a leg of a route .....	34
Deleting a Route .....	35
Viewing a Route .....	35
ODOMETER .....	36
CLEAR MENU .....	37
Clearing all Last Flxes .....	37
Clearing Track .....	38
Clearing all Waypoints .....	38
Clearing all Memory .....	38
SETUP .....	39
Initial Position .....	40
Coordinate Systems .....	40
Elevation Mode .....	40
Time Display Mode and Changing the Time .....	41
Speed Units .....	41





Distance Units .....	42
Elevation Units .....	42
North Reference .....	43
Map Datum .....	43
NMEA .....	44
Baud Rate .....	44
Waypoint Sort .....	45
Plot Setup .....	45
Contrast .....	46
SAT STATUS .....	46
Viewing the SAT STATUS Screen .....	46
SIMULATOR .....	47

### *Troubleshooting*

Troubleshooting .....	48
-----------------------	----

### *Appendix*

Icons .....	49
Warnings and Other Messages .....	50
Swivel Mounting Bracket .....	52
List of Available Datums .....	55
NMEA .....	56
City Reference Chart .....	61
Abbreviations .....	64
Specifications .....	65
What is GPS? .....	66
What is GPS? .....	66
How Does GPS Work? .....	66
Accuracy .....	67
DGPS .....	67
Where to Get More Information on GPS .....	68
Accessories .....	70
Glossary .....	72

### *Index*

Index .....	75
-------------	----

# Introduction

## **Welcome to the GPS 3000**

---

Congratulations on your purchase of the Magellan GPS 3000 satellite navigator. The GPS 3000 represents the latest technical innovation from the world's foremost GPS receiver manufacturer. Since introducing the world's very first commercial, hand-held GPS receiver in 1989, Magellan has led the way with innovative GPS products to meet a wide range of positioning and navigation needs.

Designed specifically for boating, the GPS 3000 is ideal for mapping fishing hot spots, favorite diving sites, or just finding your way around in the Great Outdoors. Magellan has established a reputation for product excellence and customer support. Our customers include sailors, commercial fishermen, pilots, geologists, explorers, surveyors and the Allied Forces in Desert Storm.

To help you get started using your new Magellan GPS 3000, turn to the section titled "Getting Started." This quick-start session will have you recording waypoint locations and navigating in no time at all. After you've learned the basics, the rest of this manual will give you detailed information about all of the features and functions of your GPS 3000 satellite navigator. A Reference Section, Troubleshooting, and Appendix with Glossary are included as well.

## **Packing List**

---

Before you begin, make sure that your package includes the following items. If any items are missing or damaged, contact Magellan immediately at (909) 394-5000 and ask for customer service.

- GPS 3000 Satellite Receiver
- Swivel mounting bracket with mounting hardware
- Carrying case
- Lanyard strap
- 4 AA Alkaline batteries
- User Manual with Quick Reference guide
- Registration Card (included in User Manual)
- Accessories order form

Optional accessories are available from Magellan Systems or your local dealer for your GPS 3000. More information and ordering instructions are included in the Appendix.

## Conventions Used in this Manual

The reference section of this manual is designed to assist you in the use of your Magellan GPS 3000. Each topic in the reference section includes a brief description of the activity chosen, a pictorial view of the keys to press, and a detailed description with sample screens of how to perform the activity. As you become more familiar with your receiver, you will be able to use the pictorial view of the keys as a "quick reference" to perform the desired activity. When you are instructed to "select" an item from a list you need to highlight the item and press ENT.

Also in the reference section are alerts to inform you of some cautions or notes that will assist you in using your Magellan GPS 3000.



The stop sign indicates the information enclosed is very important and should be read before moving on.



The Magellan logo signifies information that can help you use or understand your receiver. While this information is not required to perform the activity, it may provide you with a better understanding of the activity or shortcuts you can use.

## Commonly Used Terms

A few of the terms used in this manual may be unfamiliar to you and are described in the *Glossary* found in the Appendix. To help you get started, some of the more common terms are described here with a very simple explanation as to their meaning.

**Position Fix:** The GPS 3000 receives information from GPS satellites to compute a value (coordinates) that describes your unique position on the earth. This is called taking a **position fix** and the coordinates computed are referred to as the **position fix**. The **position fix** can be viewed on the *POSITION* screen.

**Waypoint:** (Abbreviated as WPT.) This position fix can be saved in memory with a name that you either assign or let the GPS 3000 assign for you. These saved position fixes are called **waypoints**.

**GOTO:** You can actually "Go To" any saved waypoint simply by pressing the **GOTO** key and choosing a destination waypoint. The GPS 3000 will navigate you from your present position to the waypoint chosen with bearing and distance information.



**Route:** A **route** is slightly different from a GOTO. A **route** contains a starting and ending waypoint and may include intermediate waypoints along the way. Routes can be from one waypoint to another (a single-leg route) or from a waypoint to a series of waypoints, (a multi-leg route) up to 20 legs.

**Leg:** **Legs** are the divisions of a route between waypoints. A route that goes from WPT A to WPT B, from WPT B to WPT C, and from WPT C to WPT D is said to have three **legs**.

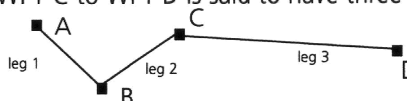

**Elevation:** The GPS 3000 calculates your **elevation** (altitude) above mean sea level.

**COG: Course Over Ground.** The Magellan GPS 3000 uses this term to define the direction the receiver is moving over the earth's surface, not necessarily the direction it is pointing.

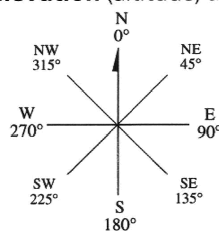

**BRG: Bearing.** Bearing is a direction, measured in degrees in a clockwise direction from north (true or magnetic depending upon which north reference is being used). **BRG** is the direction of the designated waypoint from your present position.

**CTS: Course to Steer** is the optimum direction the vessel should be steered in order to efficiently make headway back to the courseline while also proceeding toward the destination waypoint. It is a "compromise" course bearing that projects from your current position to a point on the courseline midway between a point perpendicular to your position and the current leg destination waypoint.

**DST: Distance.** The distance from current position to a given waypoint, or the distance between waypoints in a route.

**SOG: Speed Over Ground.** Actual ground speed measured as instantaneous speed.

**VMG: Velocity Made Good.** Velocity made good is that portion of the velocity [the vector component of ground speed (SOG)] that is in the direction of the destination. If the direction of travel is directly toward the destination, all of the velocity is applied toward reaching this destination. If the direction of travel is not directly toward the destination, only a portion of the velocity is applied toward reaching the destination.

## Getting Started

This section will show you how to begin using your GPS 3000 for the first time. You will learn how to:

- Install the batteries
- Initialize the receiver for the first time
- Get a position fix
- Save your first waypoint
- Create a GOTO
- Begin navigating

### GPS 3000 Description

The GPS 3000 is a self-contained hand-held GPS receiver designed for general purpose position locating and navigation. It has a built-in antenna located at the top of the receiver, a high-contrast backlit LCD, and keypad. Using four AA batteries, inserted from the battery door found at the base of the receiver, the GPS 3000 will operate continuously for up to 17 hours.

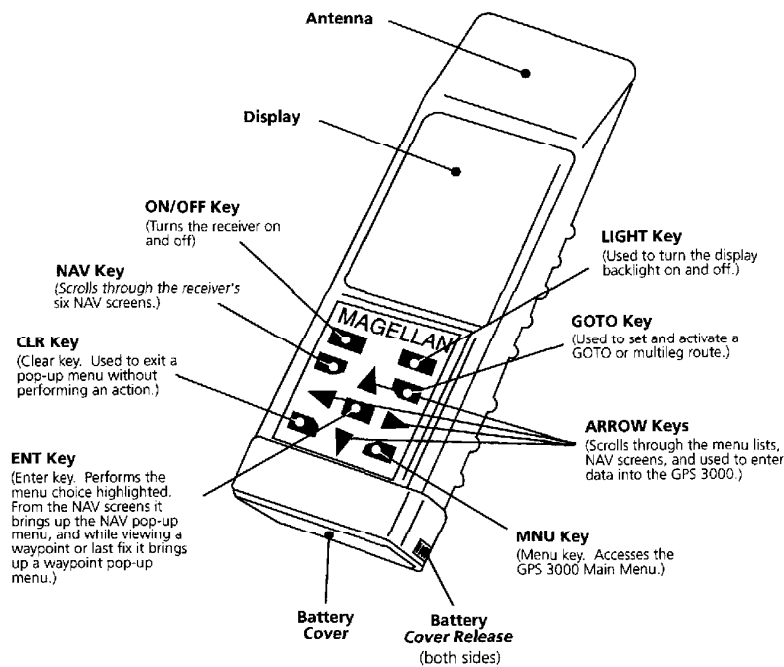

## Installing the Batteries

The GPS 3000 uses four AA alkaline batteries that are installed from the bottom of the receiver. To remove the battery cover, hold the receiver in one hand and with the other hand press in the two battery cover release tabs found on each side of the receiver. With the tabs pressed in, the battery cover can now be removed. When inserting or removing the battery cover you will notice some resistance. This is because the battery cover contains a rubber gasket to seal the battery compartment from water and dirt.

Insert the batteries as shown below and replace the battery cover. Make sure that the rubber gasket is seated correctly in the groove.

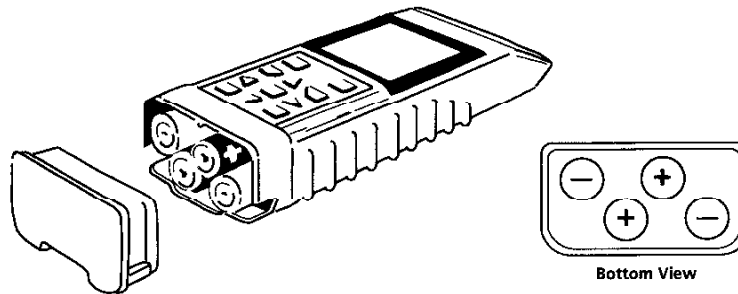

## First Time Use — Initializing the Receiver

To compute and continuously update your position, the GPS 3000 tracks signals from at least three of the 24 GPS satellites that constantly orbit the Earth. Since a GPS receiver can receive signals only from satellites that are above the horizon, it needs to know which ones to track. This is done via the almanac, built into the receiver's permanent memory and continually updated, containing a schedule of each satellite's location. In order to use its almanac, the GPS 3000 needs to know its approximate location (within 300 miles), current date, and time. When the GPS 3000 is shipped from the factory the initial position, date, and time are cleared. By initializing the GPS 3000, it will compute a position fix in a few minutes.

You can, however, compute a position fix without initializing the GPS 3000. In this case the receiver will search for all satellites in sequence and will compute a position fix when four satellites are being tracked. Obtaining a position fix without initialization can take more than 15 minutes.

You must initialize the GPS 3000 if:

- The receiver memory has been cleared. This is indicated by the latitude and longitude coordinates being at 00°00.00 and 000°00.00 respectively when you turn the receiver on.
- The receiver has been transported more than 300 miles while turned off.

## Getting Started

Magellan GPS 3000

**Step 1** Turn the receiver on by holding the **ON/OFF** key until the words "GPS 3000" are displayed on the screen (approximately 5 seconds).

**Step 2** When the POS screen appears, press the **MNU** key then the **DOWN ARROW** three times to highlight SETUP MENU.

**Step 3** Press **ENT**. (INITIALIZE is now highlighted.) Press **ENT** again. Turn to the Appendix section of this manual titled "City Reference Chart" and find the closest city (within 300 miles) to your present position.

Write the city name, latitude, and longitude that you found in the City Reference Chart for the city you have chosen.

City \_\_\_\_\_  
Latitude \_\_\_\_\_  
Longitude \_\_\_\_\_

**Step 4** Enter the latitude of your present position using the **UP/DOWN ARROWS** to scroll through the characters and the **LEFT/RIGHT ARROWS** to move the cursor.

**Step 5** If you need to toggle the last character in this line to "S" (south) press the **RIGHT ARROW** to highlight the "N." Press the **DOWN ARROW** and the "N" is toggled to an "S."

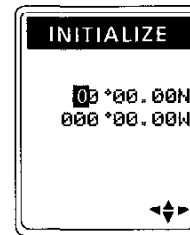

When the latitude on the display matches the latitude you found, press **ENT**.

**Step 6** Now enter the longitude for the city you chose. Making sure the *W/E* designator is correct. Press **ENT** when finished.

**Step 7** If you know your elevation (height above sea level), enter it using the **LEFT/RIGHT ARROW** and the **UP/DOWN ARROWS** as you did before. Press **ENT**. If you don't know your elevation press **ENT** to accept the present setting.

### NOTE

If the receiver is outside and in a clear view of the sky it can acquire the time and date without computing a position fix. If this happens, the receiver will not prompt you for the time and date as explained in Steps 8 and 9. To set the time refer to the Setup section, "Time Display Mode and Changing the Time."

**Step 8** Input your local time. This time needs to be within  $\pm 10$  minutes of the local time. To toggle the AM and PM designator, use the **RIGHT ARROW** to move the cursor to highlight AM or PM. The **UP/DOWN ARROWS** will toggle the designator. Press **ENT**.

**Step 9** Input today's date. When the date is correct, press **ENT**.

Congratulations! You have now initialized the GPS 3000. It now knows its approximate position and the relative position of the GPS satellites. The next step is to go outside and compute a position fix.

### Getting Signals from Satellites

Since the GPS 3000 receives the information it needs from satellites orbiting around the earth, the antenna needs to have a relatively unobstructed and a clear view of the sky.

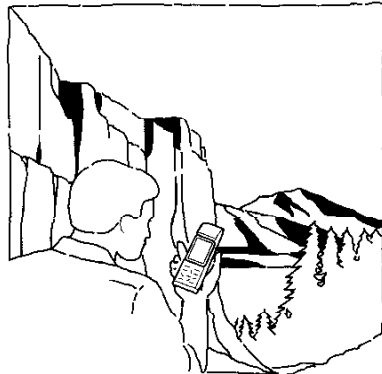

**Blocked or Partially Blocked View of the Sky.** The cliffs to the left may block the satellite signal. Physical obstructions will block satellite signals from reaching the receiver. If unable to get a position fix, move the receiver so it has a clearer view of the sky.

#### Clear View of the Sky.

The receiver has a clear view of the sky in all directions allowing it to choose from all of the satellites currently available.



## Getting Started

Magellan GPS 3000

If the view of the sky is poor (large cliffs or buildings on both sides, heavy foliage, or other obstructions) the satellite signals can be blocked and the GPS 3000 may take longer to compute a position fix.

**Holding the Receiver.** The GPS 3000 is designed to fit comfortably in your hand. Hold the receiver with the antenna above your hand and the flat portion of the antenna towards the sky.



Do **not** place or affix metallic decals or labels over the antenna portion of the receiver. Drastic reductions in signal levels can occur. This can dramatically reduce the GPS 3000's signal reception.

## Taking a Position Fix

You should be outside with a clear view of the sky before turning the receiver on. With the GPS 3000 on, press the **NAV** key until the position screen (displaying position coordinates) appears.

Following the guidelines described in *Getting Signals from Satellites* you will begin receiving signals from the satellites. The first indication will be that the word "SEARCHING" is replaced with a bar graph and the bar graph will begin filling up as more and more data is acquired. Each of the three segments of the bar graph when filled indicate the GPS 3000 is receiving (or has received all of the data) from one, two, or three satellites.

The bar graph is soon replaced with the time and date. You have just taken your first position fix and the receiver is now ready for use!

Use the following checklist if the word "SEARCHING" stays on your display for more than 5 minutes.

**Check 1** Is your view of the sky blocked? Are there any large obstructions that may be blocking the satellite signals? Is your hand covering the antenna?

**If Yes:** Move to an area that has a better view of the sky and make sure the antenna is facing up.

**Check 2** Is the latitude and longitude on the *POSITION* screen correct? Double check the N/S and the E/W designators.

**If Not:** Repeat the initialization process.

**Check 3** Is the date and time correct? Double check the AM/PM designators if using LOCAL AM/PM time. This is very important. If the date and time are incorrect the receiver may be searching for satellites that are not visible.

**If Not:** Repeat the initialization process.

### **Saving Your Position as a Waypoint**

---

You now have a position fix that defines your current position. You can save this position in the receiver's memory and navigate back to it later.

From the Position screen, or any NAV page, press **ENT, ENT, ENT**. After about 2 seconds you will see a predefined "name" for this waypoint appear above the coordinates. You could have entered a name of your own using the ARROW keys after the second ENT. The procedure for entering a name is better defined in the Reference Section under "Saving a Position as a Waypoint."

You have now stored this position in memory. It's that easy. Until you clear the waypoint or the receiver's memory, that waypoint will be there for you to use. No matter where in the world you go, as long as you can take position fixes, your GPS 3000 can guide you back to this spot.

### **Creating a New Waypoint**

---

You can also create a new waypoint with coordinates that differ from your current position. For example, let's practice by entering a waypoint for Magellan Systems Corporation in San Dimas, California.

From the *POSITION* screen press **ENT**, then press the **DOWN ARROW** to highlight CREATE WPT, and press **ENT** again.



## Getting Started

Magellan GPS 3000

This looks identical to the screen you saw when you were saving your position as a waypoint. This screen differs in that it allows you to change the coordinates and elevation of the waypoint.

Using the **LEFT/RIGHT ARROWS** and the **UP/DOWN ARROWS** you can assign a name to this waypoint following the same principles you used in initializing the receiver. Key in the name **MAGELN** for this waypoint. When you have finished, press **ENT**. Note that you could have named this waypoint anything you wanted (up to 6 characters).

Enter the latitude (34°06.58N) and the longitude (117°49.58W) for Magellan.

Enter 922 feet for the elevation.

Press **ENT**. A waypoint named "MAGELN" has now been placed into memory and is ready for you to use.

### Creating a GOTO

Very simply, a GOTO is the direct line from your current position to any waypoint you have in memory. For this example, you will create a GOTO from your current position to Magellan Systems.

Press **GOTO**. Waypoints appear in two columns of eight waypoints per column (once you have created a sufficient number of them) and the first three options are MOB, ROUTE and BCKTRK. The MOB option is highlighted. The rest of the list consists of waypoints in alphabetical order. Use the **DOWN ARROW** to highlight the waypoint MAGELN.

Press **ENT**. You have now created a GOTO. Your GPS 3000 returns to the last Nav screen viewed and immediately begins computing the information you need to get to Magellan, no matter where you are.

### Navigating with the GPS 3000

Creating the GOTO route was easy, how you use it is up to you. You have six different screens that provide you with information that you can use to navigate by.

Press the **UP/DOWN ARROWS** to cycle through the different screens. As you use your GPS 3000 you will probably find that one of the NAV screens is more suitable than the others for your particular needs. *The POSITION, NAV 1, NAV 2, POINTER, PLOTTER and ROAD* screens are constantly updating and contain the information necessary to guide you to your destination.





## POWERING THE GPS 3000

### Turning the Receiver On/Off

#### Turning the Receiver On

**ON/OFF** Hold down until GPS 3000 screen is displayed

Press the **ON/OFF** key and hold down until the "GPS 3000" screen is displayed (approximately 5 seconds). The MAGELLAN GPS 3000 copyright display will quickly flash on the screen and then the *POSITION* screen appears.

The receiver begins its search for available satellites and displays "SEARCHING" on the screen.

Once the receiver begins receiving signals from a satellite, "SEARCHING" is replaced with a sliding bar that displays the progress of the receiver in acquiring additional satellite signals.

When the receiver is tracking three or more satellites it will compute a position fix and replace the sliding bar with the current time and date. If initialized, the GPS 3000 will get your position fix within 2– 5 minutes.

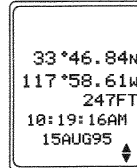
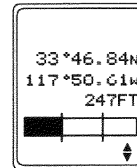
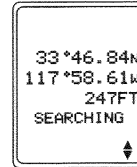
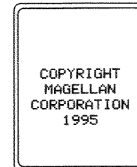

The position may be displayed in LAT/LON, UTM, TDs, OSGB, Irish, Swiss, and Swedish coordinates and the time may be displayed in 24-hour, AM/PM local time, or UT (Universal Time or Greenwich Mean Time). These options may be changed in *SETUP*. Note that in LAT/LON format, you are asked to choose between DEG/MIN.MMM and DEG/MIN.MM and DEG/MIN/SEC. This is because fractions of one minute can be expressed as decimals (hundredths and thousandths) or seconds (there are 60 seconds to one minute).

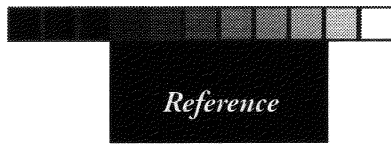

Magellan GPS 3000

### Turning the Receiver Off

**ON/OFF**

Press the **ON/OFF** key. The receiver will begin a countdown sequence that will last for 5 seconds. Pressing any key (**except ON/OFF**) will stop the receiver from turning off. Pressing the **ON/OFF** key a second time causes the unit to shut off immediately.

### Turning the Display Light On/Off

**LIGHT**

To activate the display light when the unit is on, press the **LIGHT** key. To deactivate the display light, press the **LIGHT** key again.



The GPS 3000 will indicate that the light is on with a light bulb (☼) icon at the bottom of the screen next to the arrow icons.



The display light causes an increase in battery drain resulting in shorter battery life.

### Contrast

Used to adjust the contrast of the display, regardless of whether the light is on or off.

From any  
NAV Screen

**ENT**

Select  
CONTRAST

Adjust the  
CONTRAST

From any of the six NAV screens, press the **ENT** key to activate the pop-up menu. Use the **ARROW** key to highlight **CONTRAST**.

Press **ENT**. A sliding bar graph appears below the word **CONTRAST**. Use the **LEFT/RIGHT ARROW** keys to adjust the screen contrast setting to the desired level.

Press **ENT** to return to the last viewed NAV screen, or **CLR** to return to the NAV menu.

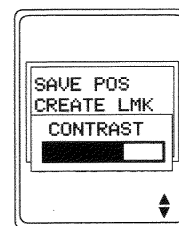

The contrast adjustment bar can also be accessed from the **SETUP** menu.



## WAYPOINTS

### Saving a Position as a Waypoint

Used to store into memory the current position as a waypoint. The waypoint's name may be created by the user, (keyed with the UP/DOWN and RIGHT/LEFT ARROWS) or created automatically by the receiver.

#### Saving the Position as a Waypoint (User-Created Name)

From any NAV Screen **ENT** Select SAVE POS Enter waypoint name **ENT**

#### Saving the Position as a Waypoint (Receiver-Created Name)

From any NAV Screen **ENT** Select SAVE POS **ENT** **ENT**

The receiver assigns a sequential waypoint name in the format WPT001, WPT002, etc. The saved position is displayed for two seconds, then the receiver returns to the last viewed NAV screen.



If you attempt to assign the same name to more than one waypoint, the message **DUPLICATE WAYPOINT NAME** appears on the screen. Press the **CLR** key to return to the **SAVE POS** screen and assign a different name.

### Creating a Waypoint

Used to create a Waypoint (WPT) with coordinates you choose. As in *Saving a Position as a Waypoint*, you can assign a name to this waypoint or have the receiver automatically generate a waypoint name.

From any NAV Screen **ENT** Select CREATE WPT Enter the waypoint name, latitude, longitude, and elevation **ENT**

From any NAV screen, press the **ENT** key. Use the **UP/DOWN ARROW** keys to highlight **CREATE WPT**.

Press **ENT** to display the **CREATE WPT** screen.

Either input a waypoint name (with the UP/DOWN and RIGHT/LEFT ARROWS) and press **ENT** or press **ENT** without entering a name and the receiver will automatically assign a name.

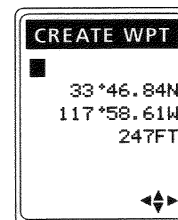

## Reference

Magellan GPS 3000

Input the desired latitude using the **UP/DOWN ARROWS** to scroll through the number list, and use the **LEFT/RIGHT ARROWS** to move the cursor left and right. With the cursor on the last character in the latitude the **UP/DOWN ARROW** toggles between N and S. Press **ENT** to confirm and continue.

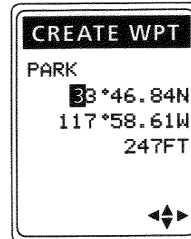

Input the desired longitude using the **RIGHT/LEFT** and the **UP/DOWN ARROWS**. With the cursor on the last character in the longitude the **UP/DOWN ARROW** toggles between E and W. Press **ENT** again to save the changes.

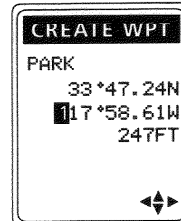

You may now input the elevation. If you do not know the elevation, press **ENT** to accept the displayed value. In a few seconds the new waypoint is saved and the receiver returns to the last viewed NAV screen.

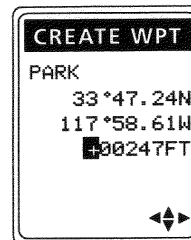

## Editing a Waypoint

This function allows you to permanently change the name, Lat/Lon or elevation of a selected stored waypoint.

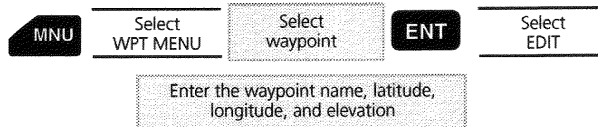

If the waypoint name you are changing is currently used in a route or is the destination of a GOTO, an error message will appear. Use the CREATE WPT function instead.

Press **MNU**. Use the **DOWN ARROW** to highlight WPT MENU and press **ENT**.

The *WPT MENU* screen appears, listing all recorded waypoints by name. Waypoint names are displayed in two columns and may continue to more than one page.

Use the **ARROW** keys to scroll through the list, which may extend to more than one screen and include up to 200 named waypoints. (Holding the arrow key down will allow the GPS 3000 to auto-scroll through the waypoint list. LEFT/RIGHT ARROWS move between columns) Highlight the waypoint whose name you wish to change, then press **ENT**.

The *WAYPOINT* screen appears, showing the name of the selected waypoint, its position and elevation.

Press **ENT** to display the waypoint function menu.

Highlight **EDIT** and press **ENT**. The *WPT EDIT* screen appears with the cursor positioned in the upper left corner.

Rename the waypoint (up to 6 characters) using the **UP/DOWN ARROWS** to go through the alphanumeric scroll, and the **LEFT/RIGHT ARROW** keys to position the cursor. Press **ENT** when you have finished renaming the waypoint. Follow the same procedure to edit the Lat/Lon and elevation, confirming each time with **ENT**. The changes are recorded and the receiver returns to the *Waypoint* screen.

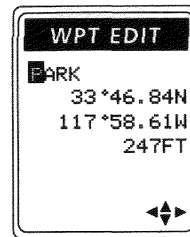

If you attempt to use a name that is already assigned to a waypoint, the message **DUPLICATE WAYPOINT NAME** appears on the screen. Press the **CLR** key to return to the *RENAME* screen and assign a different name.

## Projecting a Waypoint

Used to create a new waypoint at a specified distance and bearing from your current position or from an existing waypoint.

### To Project a Waypoint from your present position:

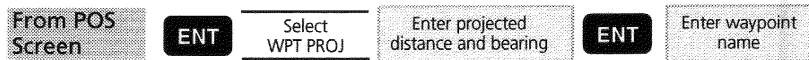

To project a Waypoint from your present position, access the POSITION screen and press **ENTER** to access the waypoint function menu.

or

### To Project a new Waypoint from an existing Waypoint :

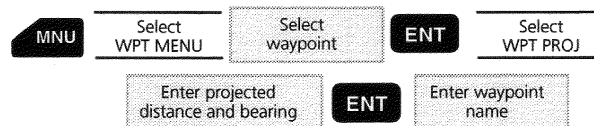

To project a Waypoint from an existing waypoint, press **MNU**. Use the **DOWN ARROW** to highlight WPT MENU and press **ENT**. Scroll using the **UP/DOWN** or **LEFT/RIGHT ARROWS** and select the waypoint from which you wish to project a new waypoint. From this waypoint screen, press **ENTER** to access the waypoint function menu.

### Then, from the waypoint function menu, select WPT PROJ.

The *WPT PROJ* screen appears with the cursor positioned on the first character in the distance field (DIST).

Use the **UP/DOWN** and **RIGHT/LEFT ARROWS** to key in the distance at which you wish to project the new waypoint. When you have finished, press **ENT** to confirm and continue.

```

    WPT PROJ
    FROM POS
    DIST 000.0
    BRG
  
```

The cursor appears in the bearing field (BRG). Use the **UP/DOWN** and **RIGHT/LEFT ARROWS** to key in the bearing at which you wish to project the new waypoint. When you have finished, press **ENT** to confirm.

The coordinates of the projected waypoint you have just created appear on the WPT PROJ screen. To save this waypoint, press **ENT**, assign a name using the **UP/DOWN** and **RIGHT/LEFT ARROWS**, then press **ENT**. Pressing **CLR** returns you to the pop-up menu.

## Viewing a Stored Waypoint

The receiver has a storage capacity of 200 waypoints. Each one may be viewed through the menu of waypoint names.





Press **MNU**. Use the **DOWN ARROW** to highlight WPT MENU.

Press **ENT**. The *Waypoint List* appears, listing all recorded waypoints in two columns, displayed alphabetically or in order of closest to farthest from your current position (NEAREST).

Use the **UP/DOWN** and **RIGHT/LEFT ARROWS** to scroll through the list, which may extend to more than one screen and include up to 200 named waypoints.

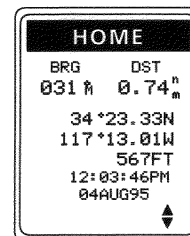
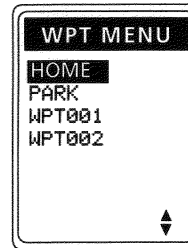
Press **ENT** to view the stored waypoint.



 While you are viewing a stored waypoint you can use the UP/DOWN ARROWS to page through the other waypoints in the list.

When you have finished viewing the waypoints, press the CLR key to return to the previous menu, or the NAV key to exit.

## Deleting a Waypoint

Permanently removes a saved waypoint from the receiver's memory.



Press **MNU** key, then use the DOWN ARROW to highlight WPT MENU. Press **ENT**. The Waypoint List screen appears, displaying the names of all recorded waypoints.

Use the **UP/DOWN ARROWS** to highlight the waypoint you wish to delete and press **ENT**.



Reference

Magellan GPS 3000

A waypoint information screen will appear showing the name, coordinates, bearing, distance and time and date of the selected waypoint.

Press **ENT** to access the waypoint function menu.

Use the **DOWN ARROW** to highlight DELETE and press **ENT**.

A **WARNING** screen is displayed with the word YES highlighted.

If you are certain that you wish to delete this waypoint, then press **ENT**. The waypoint is cleared and the receiver displays the position screens for next waypoint in the waypoint list.

If you do not wish to erase this waypoint, highlight the word NO, then press **ENT**. The screen showing the selected waypoint reappears.

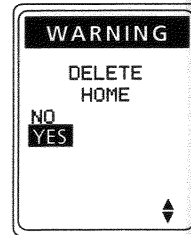

 If a waypoint is contained in a route or a GOTO, it cannot be deleted without first clearing the route or reassigning a GOTO.

### LAST FIX Buffer

While the GPS 3000 is operating and taking position fixes it automatically saves a position (last fix) every 10 minutes and stores it in a special area called the LFIX buffer. The LFIX buffer, which contains up to 21 last fixes, is used when you activate the Backtrack function. When 21 fixes have been saved, the next fix is added and the oldest last fix is removed.



To edit, view, or clear a LFIX waypoint, press **MNU**, and using the **DOWN ARROW**, select LAST FIXES.

Press **ENT** to display the position screen for LFIX01 with the bearing and distance to the last fix and the time and date it was taken.

Use the **UP/DOWN ARROWS** to scroll through the last fix buffer. (The **DOWN ARROW** goes back to earlier fixes.)

Press **ENT** from any of these last fix screens to call up the function menu, and select the desired function COPY TO, DELETE or CREATE.



## COPYING a Last Fix as a Waypoint

This function allows you to copy a last fix to the Waypoint List.



Press **MNU**, **DOWN ARROW** and select LAST FIXES.

Press **ENT** to display the screen for LFIX01 with the bearing and distance to the last fix and the time and date it was taken.

Use the **UP/DOWN ARROW**s to scroll through other fixes in the last fix buffer. (The DOWN ARROW goes back to earlier fixes.)

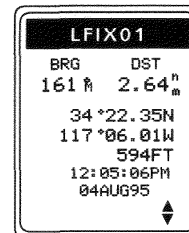

Press **ENT** from any last fix screen to call up the function menu, and select COPY TO.

Press **ENT** to access the RENAME screen.

Using the **UP/DOWN** and **RIGHT/LEFT ARROW**s, assign a name to the selected last fix to record it as a named waypoint (up to 6 characters) without deleting it from the Last Fix Buffer. Press **ENT** when you have finished renaming the waypoint.

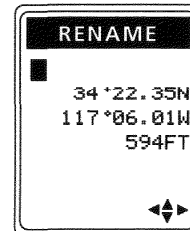

## DELETING a Last Fix



Press **MNU**, **DOWN ARROW** and select LAST FIXES.

Press **ENT** to display the position screen for LFIX01 with the bearing and distance to the last fix and the time and date it was taken.

Use the **UP/DOWN ARROW**s to scroll through other fixes in the last fix buffer. (The DOWN ARROW goes back to earlier fixes.)

From the screen showing the Last Fix you wish to delete press **ENT** to call up the function menu, and select DELETE. Press **ENT**.

A confirmation screen appears with the word YES highlighted. If you are certain that you wish to erase this Last Fix, press **ENT**.

If you do not wish to delete this Last Fix, highlight NO, then press **ENT**.



Last fixes are used to create backtrack routes; if you delete all last fixes, it will not be possible to create a backtrack until more last fixes are available.

## GOTO (Activating)

This creates and activates a GOTO, a single leg route from your current position to the waypoint you select from the GOTO waypoint list.

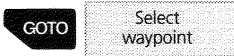

Press **GOTO**. A list of all recorded waypoints, the MOB, ROUTE and BCKTRK options, appears on the *GOTO* screen.

Use the **UP/DOWN** or **RIGHT LEFT ARROWS** to highlight the waypoint to be used as the destination. The list of waypoints may extend to more than one screen as the GPS 3000 can store up to 200 waypoints. Press **ENT**.

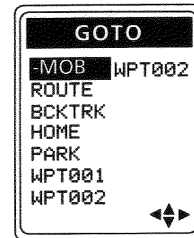

If the receiver is not locked and tracking satellites, the start of GOTO will be the last position computed, not necessarily the current position.

**MOB** Immediately sets a route to the last position calculated at the time when the GOTO key was first pressed. If a MOB route already exists, a warning screen appears. To cancel and replace the first MOB, select YES. To keep the existing MOB select NO. The display returns to the last viewed NAV screen.

**ROUTE** Used to activate a route that is in memory and is not active. Selecting this option takes you to the ROUTE MENU. See Activating a Route for more details.

**BACKTRACK** The BACKTRACK option creates a backtrack route by copying the 21 last fixes to the first available route ("X") in the format -BX-01, -BX-02 etc. The screen displays CREATING BACKTRACK PLEASE WAIT, then automatically activates the backtrack route and returns to the last viewed NAV screen.



If all routes are full when BCKTRK is selected, the unit displays the message "ROUTES FULL - CLEAR ROUTE TO CONTINUE."

## NAV

### Viewing the NAV Screens

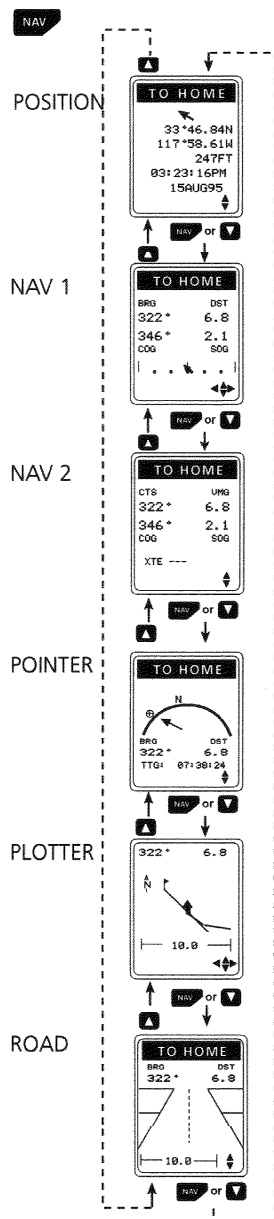

The GPS 3000 will display your position and progress towards your destination on six different navigation screens that can be accessed by pressing the NAV key.

#### NAV Screens Flow Chart

Once you are viewing a NAV screen you can scroll to the next by using the UP or DOWN ARROW. Pressing the NAV key will scroll in the same direction as the DOWN ARROW.

The *POSITION* screen displays the coordinates, date and time of your current location, which you can compare to a map. It also displays an arrow pointing to your destination if a GOTO or route has been set, and the name of the destination waypoint of the current leg.

The NAV 1, NAV 2 and POINTER screens display information that will help you arrive at your destination.

The *PLOT* screen displays a graphical representation of your travels relative to your planned route.

The *ROAD* screen displays a graphical representation of cross track error and Course Deviation Indicator.

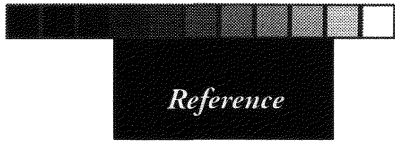

**POSITION screen**

This screen displays present position, elevation, time of day and, if a route or GOTO is active, a pointer indicating the general direction to travel to reach the destination waypoint based on your current direction of travel. If you are not moving, the arrow points to your destination relative to north. From any of the navigation screens access the *POSITION* screen by pressing NAV or the UP/DOWN ARROWS repeatedly.

**POSITION Screen (LAT/LON Coordinates)**

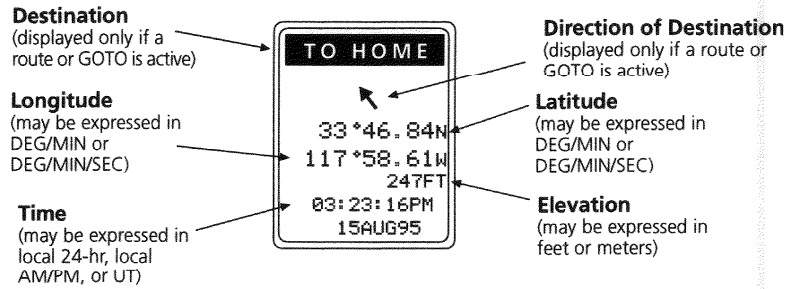

**POSITION Screen (UTM Coordinates)**

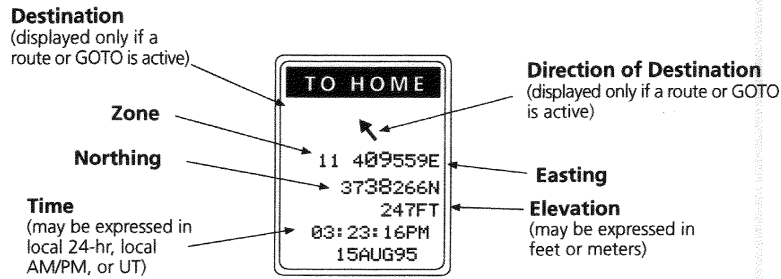

Other coordinate systems are also available in the GPS 3000. If you are using another system, the coordinates will appear differently.

**SUN/MOON**

The Sunrise feature provides sunrise, sunset and lunar visibility information for the selected position on the entered date.

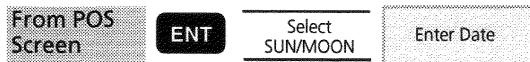

*Reference*

From the POSITION screen, press **ENT**. Highlight SUN/MOON and press **ENT**.

The cursor appears on the first character of the current date. Confirm the date by pressing **ENT**, or use the **UP/DOWN** and **RIGHT /LEFT ARROWS** to key in a different date, then press **ENT**.

The moon symbol at right represents a three-quarters moon.

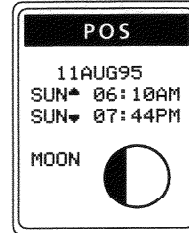

The times of the sunrise and sunset for the selected date and position appear, as well as a graphic representation of lunar visibility.

**NAV 1 screen**

If the receiver has an active route or GOTO and is computing position fixes, this screen gives the bearing (BRG) and distance (DST) to the destination waypoint of the current leg. In addition, if you are moving, the course over ground (COG) and speed over ground (SOG) are displayed. Access this screen using the **UP/DOWN ARROWS** from any of the other five NAV screens or by pressing **NAV** repeatedly.

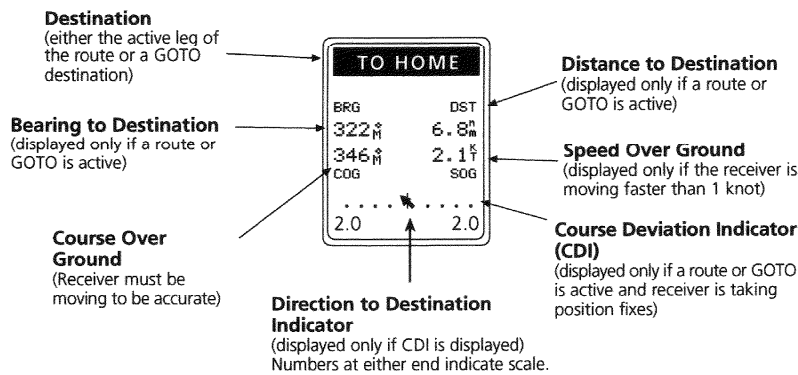

**Course Deviation Indicator (CDI).** The CDI is a graphical indication of your position relative to your planned course. The **Direction to Destination** indicator will be located on one of the dots or in the center of the CDI giving you an indication of how far left or right of the planned course you are and the direction you need to turn to get to the destination.

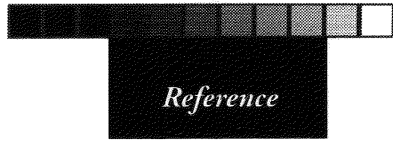

Magellan GPS 3000

The distance units (miles, nautical miles, or kilometers) can be selected from the Setup menu and you can use the **RIGHT/LEFT ARROWS** to change the scale. Each dot represents a quarter unit.

.....↑..... With the arrow in the center you are on course. With the arrow pointing straight ahead you should continue moving in the same direction you are heading to arrive at the destination. If the arrow points downward, you are on the course line, but traveling in the opposite direction. If the receiver is not moving, the arrow points up as a default.

.....|↖..... With the arrow on the first dot to the right, you are to the right of the course line. The arrow points approximately 45° to the left so not only do you need to move to the left, you need to turn to the left as well.

.....|←..... The horizontal arrow on the third dot to the left indicates you are traveling in a direction approximately 90° to the left of your destination.

## NAV 2 screen

If the receiver has an active route or GOTO and is computing position fixes, this screen gives the course to steer (CTS) and velocity made good (VMG) to the destination waypoint of the current leg. In addition, if you are moving, the course over ground (COG) and speed over ground (SOG) are displayed. Access this screen using the **UP/DOWN ARROWS** from any of the other five NAV screens or by pressing **NAV** repeatedly.

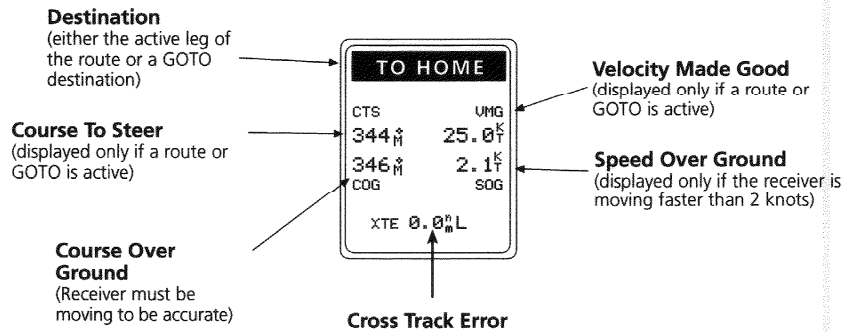

**Cross Track Error (XTE)** is represented numerically in the lower part of the screen in the selected distance units, followed by R or L, according to whether the cross track error is right or left of the courseline.

The cross track error value is displayed to one decimal place for distances of 9.9 distance units or less, and to the nearest distance unit for distances over 9.9 distance units.

### POINTER screen

If there is an active GOTO or route this screen points to your destination and displays bearing, distance, and Time To Go to reach the destination. Access this screen using the **UP/DOWN ARROWS** from any of the other five NAV screens. If you are moving, the top of the screen is referenced to the direction you are moving, otherwise, the top of the screen is referenced to North.

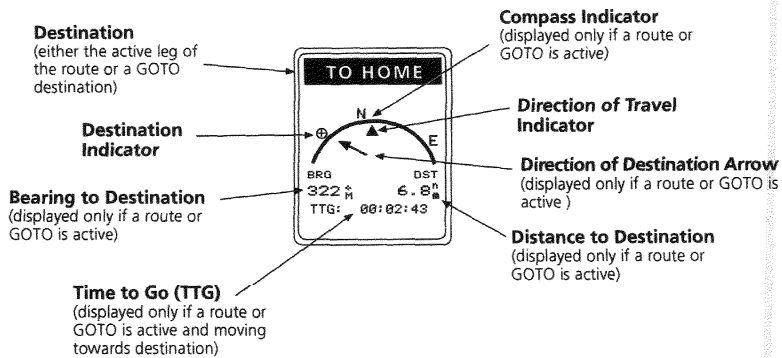

If the destination is more than 90° to the left or right of your current position, the Destination Indicator ⊕ disappears but the Direction of Destination arrow → will still point towards the destination. The Direction of Travel indicator, ▲, is displayed when you are moving. The top of the screen is referenced to your direction of travel. If the Direction of Travel indicator is not shown, then the receiver is not moving and the top of the screen is referenced to North.

The Direction of Destination arrow appears when a route or GOTO is active. If the receiver is moving, the top of the display should be pointed straight in front of you so that the arrow will indicate which way you need to turn to head toward the destination waypoint. If you are not moving, the arrow still appears but the top of the display is referenced to North.

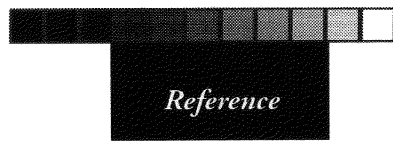

Magellan GPS 3000

### PLOTTER screen

This screen provides you with a track history of your route travelled, and your bearing and distance to the destination indicated at the top of the screen. Access this screen using the **UP/DOWN ARROWS** from any of the other five NAV screens.

The Direction indicator (located in the center of the screen) is also your current position as it relates to the plot drawn. The screen is dynamic and updates as you are viewing this display.

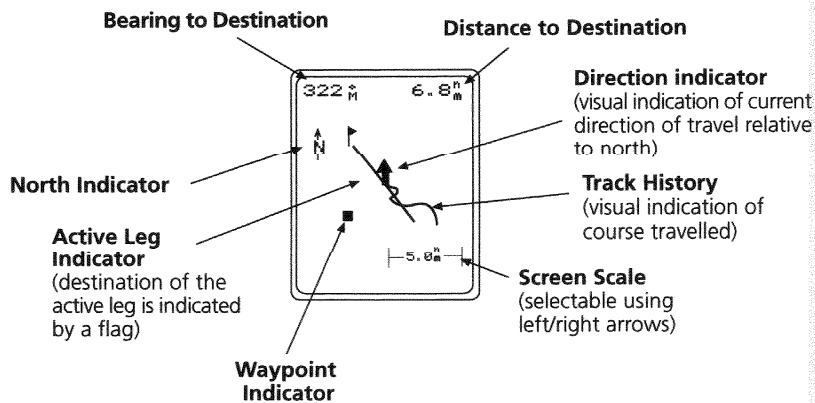

The Screen Scale is shown in the lower portion of the display. Using the **RIGHT/LEFT ARROWS**, adjust the screen scale to 0.1, 0.25, 0.5, 1, 2.5, 5, 10, 25, 50 distance units.

### PAN N SCAN

The GPS 3000 is equipped with a PAN N SCAN feature that allows you to access waypoint information relative to your position by placing the cursor over the waypoint on the Plotter screen

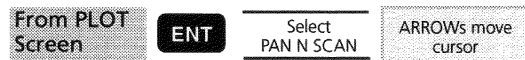

From the Plotter screen, press **ENT** to access the NAV MENU. You will notice that this menu is different from the NAV MENU accessed from other navigation screens in that it has two additional features, PAN N SCAN and DELETE TRK.

Highlight PAN N SCAN and press **ENT**.





The PAN N SCAN screen is similar to the PLOTTER screen, however a vertical and horizontal line cross to form a cursor.

Use the **UP/DOWN** and **RIGHT/LEFT ARROWS** to move the cursor anywhere on the screen or beyond.

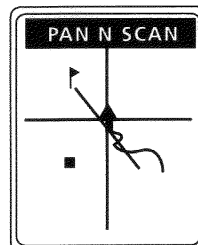

When the cursor covers a waypoint on the screen, represented by a solid square, the screen's title bar displays the name of the waypoint.

Just below the waypoint name, the bearing (BRG) and distance (DST) to reach the waypoint covered by the cursor are displayed.

Waypoints are represented by ■, Destinations are represented by ▲.

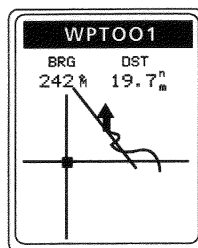

To set a GOTO to the waypoint covered by the cursor, when the waypoint information is displayed, press **ENT**.

A GOTO confirmation screen appears. Select YES to create the GOTO, or NO to return to the PAN N SCAN screen, and press **ENT**. Or press **CLR** to return to the PAN N SCAN.

### Delete Track

The DELETE TRK option in the plotter screen NAV menu allows you to clear track history on the PLOTTER screen.

From the PLOTTER screen, press **ENT** to access the PLOTTER screen NAV menu. Highlight DELETE TRK and press **ENT**.

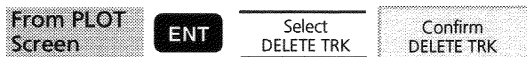

A confirmation screen appears. Select YES to erase track, or NO to return to the PLOTTER screen without erasing track and press **ENT**. To exit the confirmation screen and return to the NAV menu press **CLR**.



Since the receiver stores the track history, it is advisable to delete the track before navigating on a new route or GOTO to avoid unnecessary clutter on the PLOT screen.

## ROAD Screen

The Road Screen provides a graphical representation of cross track error and a course direction indicator. Access this screen using the **UP/DOWN ARROWS** from any of the other five NAV screens.

Use the **RIGHT LEFT ARROWS** to adjust the scale of the CDI.

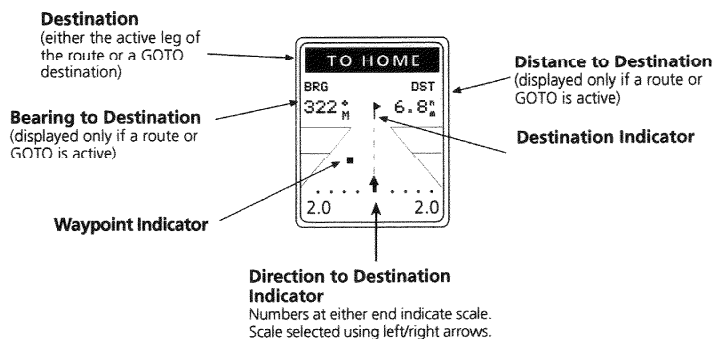

## ROUTES

### Accessing the Route Menu

The Route Menu is used to view a one-page list of up to five existing routes. A pop-up menu allows you to activate or deactivate, reverse, edit or delete the selected route, or view the legs of the route.

There are three ways of accessing the Route Menu.

Method 1: **MNU** Select  
ROUTE MENU

Press **MENU** to access the Main Menu and select ROUTE MENU.

**OR**

Method 2: **From any NAV Screen** **ENT** Select  
ROUTE MENU

From any NAV screen, press **ENT** to access the submenu and select ROUTE MENU.

**OR**

Method 3: **GOTO** Select  
ROUTE

Press **GOTO** to access the GOTO screen and select ROUTE.



Magellan GPS 3000

 Press **CLR** to return to the NAV menu, GOTO menu or Function menu, depending on how the Route menu was accessed.

### Creating a Route

This function allows the creation of up to five multileg routes using any waypoint in memory. A route may contain from 1 to 20 legs.

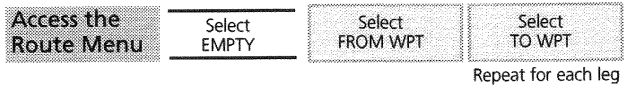

Access the ROUTE MENU by pressing **MNU, DOWN ARROW**, then **ENT** or from any NAV screen press **ENT, DOWN ARROW** to highlight ROUTE MENU, and **ENT**, or press **GOTO**, select ROUTE and press **ENT**.

The Route menu screen is displayed with five routes on one page. Use the **UP/DOWN ARROWS** to scroll through the routes.

Highlight an EMPTY route and press **ENT**.

 If there are no empty routes in the Route Menu, you must clear a route before you can create a new one.

If you have a current position fix the first "FROM" waypoint will be -STRTx. This waypoint represents your current position. You can select -STRTx if you want your route to begin at your current position.

## Reference

Magellan GPS 3000

Use the **LEFT/RIGHT ARROWS** to scroll through the list of waypoints and select the point of departure (FROM) for the first leg of the route. Press **ENT**.

```
ROUTE 1
LEG 01
FROM HOME
TO
```

The selection is recorded and the cursor steps down to the TO line. Use the **LEFT/RIGHT ARROWS** to select the destination (TO) for the first leg of the route. The bearing and distance to the destination for this leg is also displayed and updated as you scroll through the various TO waypoints. Press **ENT** when the desired waypoint is displayed.

```
ROUTE 1
LEG 01
FROM HOME
TO PARK
BRG 189° DST 12.4
```



The receiver will not accept the entry if the FROM waypoint and the TO waypoint have the same position or are less than .1 nm from each other.

The screen now shows LEG 02 of the route. You may continue to create this and other legs of the route by using the **LEFT/RIGHT ARROWS** and confirming with **ENT** each time. When you have added as many legs to the route as desired (up to 20 legs), press **ENT** with the TO field blank. After creating the route, the receiver returns to the NAV screen, the GOTO menu or the Main Menu depending upon how you accessed the Route Menu.

```
ROUTE 1
LEG 02
FROM PARK
TO
BRG DST
```

Once a route has been created, it may be **ACTIVATED** or **DEACTIVATED** (depending upon its current state), **REVERSED**, **EDITED**, **DELETED** or **VIEWED** (leg by leg). When a full route is highlighted, press **ENT** to view these options on the pop-up menu.

When you create a new route, this route automatically becomes the active route and the GPS 3000 begins navigating the first leg of the route, shown on the NAV screens.

## Deactivating a Route

Used to deactivate (turn off) a route that is currently in use. The route is retained in memory and can be activated again.

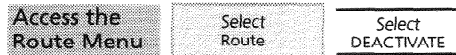

To deactivate a route, access the ROUTE MENU and highlight the desired route. Press **ENT**. The word **DEACTIVATE** is highlighted at the top of the pop-up menu if the route is currently active.

Press **ENT** to deactivate the route.

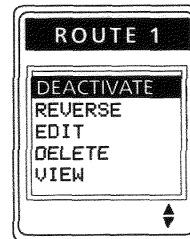

Selecting a new GOTO waypoint (see *Creating a GOTO Route*) will also deactivate an existing route.

## Activating a Route

Used to activate (turn on) a route that had been previously deactivated.

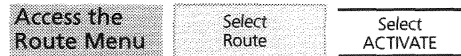

Access the ROUTE MENU. Highlight the desired route and press **ENT**.

The word **ACTIVATE** is highlighted at the top of the pop-up menu if the route is currently deactivated. Press **ENT** while **ACTIVATE** is highlighted to activate the route. After activating the route, the receiver returns to the last viewed NAV screen.

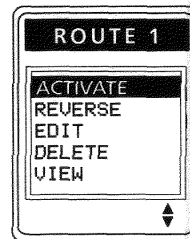

## Reversing a Route

Reverse Route takes the route currently in memory and makes a mirror image of the route enabling you to return to your starting point following the same route.

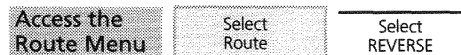

Access the ROUTE MENU.. Select the desired route and press **ENT** to access the pop-up menu. Use the **DOWN ARROW** key to highlight REVERSE and press **ENT**. After reversing the route the receiver returns to the Route Menu.

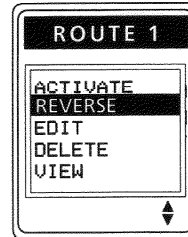

## Editing a Route

The edit option displays a summary of the selected route, including starting and ending waypoints, number of legs, and total distance of the route. It allows you to view, insert, delete and replace individual legs of a route.

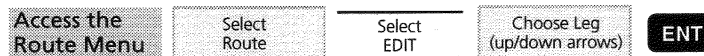

Access the ROUTE MENU. Select the desired route and press **ENT** to access the pop-up menu.

Use the **DOWN ARROW** key to highlight EDIT and press **ENT**.

The summary page appears for the selected route, showing the starting and ending waypoints, the number of legs and total distance.

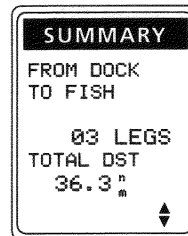

Use the **UP/DOWN ARROWS** to scroll through the consecutive legs of the route. Pressing the **DOWN ARROW** displays Leg 1, Leg 2 and so forth. Pressing the **UP ARROW** displays the previous leg.

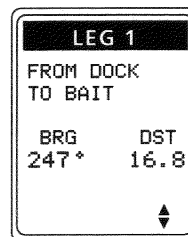

From the page displaying the leg of the route you wish to edit, press **ENT** to access the EDIT menu. The word **INSERT** is highlighted.

### ***Inserting a waypoint from the leg edit menu***

This option allows you to insert a waypoint between the starting and ending points of the selected leg in the route.

Access the ROUTE MENU. Use the **DOWN ARROW** key to highlight EDIT and press **ENT**.

Use the **UP/DOWN ARROWS** to scroll through and highlight the leg of the route in which you wish to add a waypoint.

Press **ENT** to access the LEG EDIT menu, highlight INSERT and press **ENT**.

The cursor appears in the TO field.

Use the **RIGHT/LEFT ARROWS** to scroll through the list of waypoints until you reach the waypoint you wish to insert in the leg displayed. Press **ENT**.

If you wish to cancel and escape, press **CLR**.

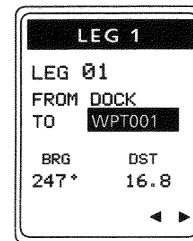

The waypoint you insert must be different from the original starting and ending waypoints by at least 0.1 distance units (i.e. 0.1 nautical miles).

The screen returns to the leg edit menu.

When a new waypoint is inserted in a leg, the existing leg becomes two legs and the numbering of the legs in the route adjusts to accommodate the new waypoint.

### ***Deleting a leg using the leg edit menu***

This function allows you to delete the destination waypoint of a leg in a route, thereby deleting the leg itself, and leaving the route unbroken.

Access the ROUTE MENU. Select the desired route and press **ENT** to access the pop-up menu.

Use the **DOWN ARROW** key to highlight EDIT and press **ENT**.

Use the **UP/DOWN ARROWS** to scroll through and highlight the leg of the route you wish to delete.

Press **ENT** to access the LEG EDIT menu, highlight DELETE and press **ENT**.

A confirmation screen appears. Select YES and press **ENT** to delete the destination waypoint shown, or select NO and press **ENT** to cancel. The screen returns to the route summary.

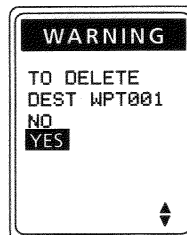

### Replacing a waypoint in a route

Access the ROUTE MENU. Select the desired route and press **ENT** to access the pop-up menu.

Use the **DOWN ARROW** key to highlight EDIT and press **ENT**.

Use the **UP/DOWN ARROWS** to scroll through and highlight the leg whose destination waypoint you wish to replace. Press **ENT** to access the LEG EDIT menu, highlight REPLACE and press **ENT**.

Use the **RIGHT/LEFT ARROWS** to scroll through the list of waypoints until you reach the waypoint you wish to insert in place of the destination waypoint of the leg displayed. Press **ENT**.

If you wish to cancel and escape, press **CLR**. When the leg is replaced, the screen returns to the LEG EDIT menu.



The waypoint you insert to replace must be different from the original starting and ending waypoints by at least 0.1 distance units (i.e., 0.1 nautical miles).

### Activating a leg of a route

This function allows you to select a leg in a route using the LEG EDIT menu and make that leg the active leg.

Access the ROUTE MENU. Select the desired route and press **ENT** to access the pop-up menu. Use the **DOWN ARROW** key to highlight EDIT and press **ENT**.

Use the **UP/DOWN ARROWS** to scroll through and highlight the leg you wish to activate, then press **ENT**. To access the pop-up menu, choose activate and then press ENT.

The selected leg is activated and the display returns to the position screen showing the active leg. The receiver begins navigating toward the destination waypoint of the activated leg.

### Viewing a leg of a route

This function allows you to view a graphical representation of a selected leg in a route, including the bearing and distance from the starting and ending waypoints of the leg.



Access the ROUTE MENU. Select the desired route and press **ENT** to access the pop-up menu.

Use the **DOWN ARROW** key to highlight EDIT and press **ENT**.

Use the **UP/DOWN ARROWS** to scroll through and highlight the leg you wish to view.

Press **ENT** to access the LEG EDIT menu, highlight VIEW and press **ENT**.

The selected leg is displayed as an arrow between two waypoints, indicating the bearing and distance from the starting waypoint to the destination waypoint of that leg.

### Deleting a Route

DELETE allows you to permanently clear a route from memory.



Access the ROUTE MENU. Highlight the route you wish to delete and press **ENT** to access the pop-up menu. Use the **DOWN ARROW** key to highlight DELETE and press **ENT**.

A WARNING screen is then displayed requesting confirmation that you want to clear the route from memory.

Using the **UP/DOWN ARROW** keys, choose YES to confirm the CLEAR function, erasing the route from memory; or NO to abort the CLEAR function and return to the Route Menu. After making your selection press **ENT**.

You may clear a route from memory whether it is activated or deactivated.

### Viewing a Route

VIEW enables you to graphically look at each leg of the route in memory and change the active leg.



Access the ROUTE MENU. Select the desired route and use the **DOWN ARROW** to highlight VIEW. Press **ENT**

The *ROUTE* screen appears, showing a graphic representation of the first leg of the route.

Use the **UP/DOWN ARROWS** to view other legs of the route successively.

The word **ACTIVE** appears on the screen showing the active leg of the route.

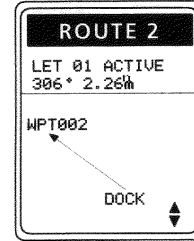

**To Activate a Route Leg.** Press **ENT** while viewing a leg to activate that leg.



The GPS 3000 will automatically activate the next leg of the route once you reach the destination of the current leg.

## ODOMETER

This feature displays the **ODOMETER** screen which keeps track of total distance traveled as well as trip distance, similar to the odometer in an automobile.

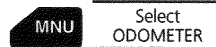

Press **MNU** to access the Main Menu screen. Use the **UP/DOWN ARROWS** to highlight **ODOMETER** and press **ENT**.

The **ODOMETER** screen appears, showing the total distance traveled and the distance traveled on the current trip.

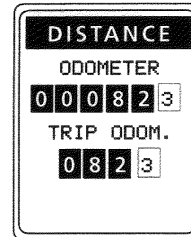

### To reset the odometer:

Press **ENT** to display the reset menu. Use the **UP/DOWN ARROWS** to highlight **RESET ODOM** and press **ENT**. (If you do not wish to clear the odometer, press **CLR** to escape back to the main menu.)

A confirmation screen appears. Select **YES** and press **ENT** if you wish to reset, or select **NO** and press **ENT** to return to the **ODOMETER** screen without resetting.

Magellan GPS 3000

### To reset the trip odometer:

Press **ENT** to display the reset menu. Use the **UP/DOWN ARROWS** to highlight RESET TRIP. (If you do not wish to clear the trip odometer, press **CLR** to escape back to the main menu.)

A confirmation screen appears. Select YES and press **ENT** if you wish to reset, or select NO and press **ENT** to return to the ODOMETER screen without resetting.

## CLEAR MENU

The Clear Menu is used to globally delete last fixes, track, waypoints or everything in the memory.

Press **MNU** to access the Main Menu screen. Use the **UP/DOWN ARROWS** to highlight CLEAR MENU and press **ENT**.

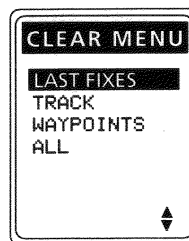

Use the clear menu **only** when you wish to delete an entire category of waypoints; *individual* waypoints or last fixes are deleted in the Waypoint or Last Fix menus (see Deleting Waypoints or Deleting Last Fixes.)

## Clearing all Last Fixes

This function clears all the Last Fixes from the Last Fix Buffer.

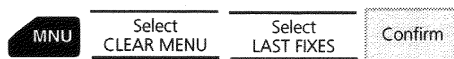

Press **MNU** to access the Main Menu screen. Use the **UP/DOWN ARROWS** to highlight CLEAR MENU and press **ENT**.

Select LAST FIXES and press **ENT**.

A confirmation screen then appears. Choose YES to confirm the clear function, or NO to abort and return to the CLEAR MENU screen.

## Clearing Track

This function deletes the track created on the plotter screen.

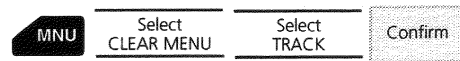

Press **MNU** to access the Main Menu screen. Use the **UP/DOWN ARROWS** to highlight CLEAR MENU and press **ENT**.

Select TRACK and press **ENT**.

A confirmation screen then appears. Choose YES to confirm the clear function, or NO to abort and return to the CLEAR MENU screen.

## Clearing All Waypoints

This function clears all the Waypoints from the Waypoint List.

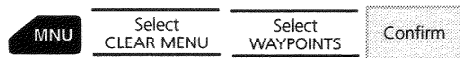

Press **MNU** to access the Main Menu screen. Use the **UP/DOWN ARROWS** to highlight CLEAR MENU and press **ENT**.

Select WAYPOINTS and press **ENT**.

A confirmation screen then appears. Choose YES to confirm the clear function, or NO to abort and return to the CLEAR MENU screen.

## Clearing All Memory

This function clears all user-entered memory and turns the unit off.

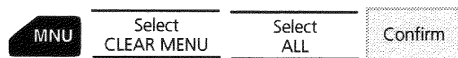

Press **MNU** to access the Main Menu screen. Use the **UP/DOWN ARROWS** to highlight CLEAR MENU and press **ENT**.

Select ALL and press **ENT**.

A confirmation screen then appears. Choose YES to confirm the clear function, or NO to abort and return to the CLEAR MENU screen.

## SETUP

Accessed from the Main Menu, Setup allows you to configure the receiver for your particular needs. Setup is also where you initialize the receiver by entering the approximate coordinates of your position to assist the receiver in getting the information it requires the first time you use the receiver, or in the unlikely event that it loses its memory.

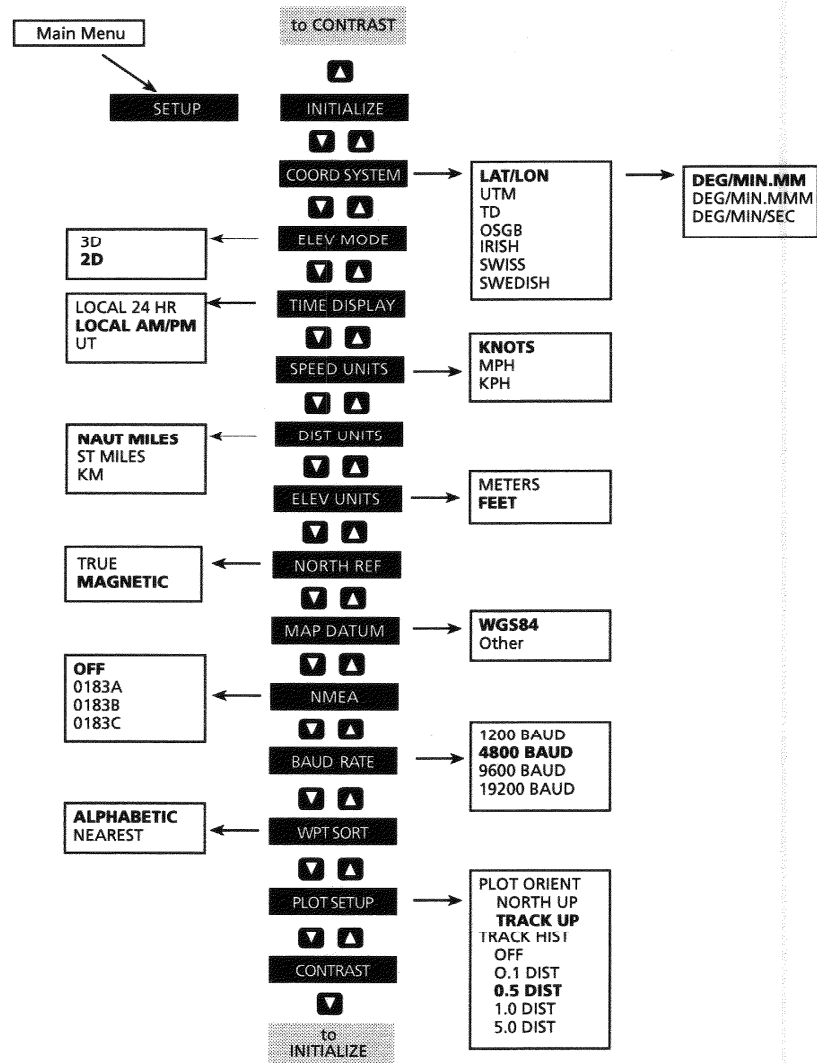

Default values shown in bold text.

## Initial Position

Allows you to establish the initial position for the receiver. This will enable the receiver to quickly search the sky for the satellites available in your area. See the *Getting Started* section for details on initializing your receiver.

## Coordinate Systems

This option allows you to select the coordinate system that you will be entering and viewing your position in. The most common is LAT/LON which uses the lines (parallels and meridians) of latitude and longitude projected onto the earth and encircling it. Also available in the GPS 3000 are UTM, TDs, British Grid, Irish Grid, Swiss Grid and Swedish Grid.

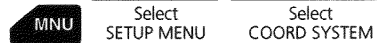

Press **MNU** and use the **UP/DOWN ARROWS** to highlight SETUP MENU and press **ENT**. Use the **UP/DOWN ARROWS** to highlight COORD SYSTEM and press **ENT**.

Use the **UP/DOWN ARROWS** to select the coordinate system and press **ENT**.

Default values:

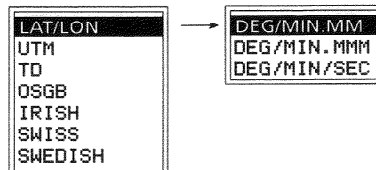

If you select LAT/LON you will be asked if you want DEG/MIN.MMM or DEG/MIN.MM and DEG/MIN/SEC. The coordinate system you ultimately select will depend upon the maps or charts that you use with your receiver.

## Elevation Mode

There are two options to choose from in setting the elevation mode; 3D (3-Dimensional) or 2D (2-Dimensional).



3D: Requires that at least four satellites be in view and spread out properly in the sky to compute a position fix, and **will** compute elevation. If only three satellites are in view while in the 3D mode, the GPS 3000 will automatically switch to 2D and stay in 2D until a fourth satellite is available.

2D: Requires at least three satellites in view to compute a position fix but **will not** compute elevation. Displayed elevation will be the last computed or user-entered elevation. A "2D" icon will appear at the bottom of the screen when the last fix taken is in the 2D mode.

Press **MNU** and use the **UP/DOWN ARROWS** to highlight SETUP MENU and press **ENT**. Use the **UP/DOWN ARROWS** to highlight ELEV MODE and press **ENT**.

Use the **UP/DOWN ARROWS** to highlight your selection, (3D or 2D), then press **ENT**. The screen returns to the SETUP menu.

Default value:

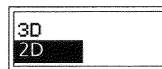

If 2D is selected, the 2D icon will not appear on the bottom row of the display until **after** a position fix has been computed.

### Time Display Mode and Changing the Time

Allows you to select the mode that you want time displayed in. Can be set to local 24-hour, local 12-hour (AM/PM), or UT (universal time).

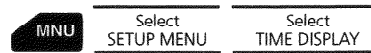

Press **MNU** and use the **UP/DOWN ARROWS** to highlight SETUP MENU and press **ENT**. Use the **UP/DOWN ARROWS** to highlight TIME DISPLAY and press **ENT**.

Use the **UP/DOWN ARROWS** to select the mode desired; LOCAL 24HR, LOCAL AM/PM, or UT and then press **ENT**. After selecting LOCAL 24HR or LOCAL AM/PM you are prompted to enter the current local time. Use the **UP/DOWN ARROWS** to change local time. The time you enter needs to be within 10 minutes of the correct time. Press **ENT** when finished.

Default value:



### Speed Units

Allows you to select the unit of measure for speed measurements.



Press **MNU** and use the **UP/DOWN ARROWS** to highlight **SETUP MENU** and press **ENT**. Use the **UP/DOWN ARROWS** to highlight **SPEED UNITS** and press **ENT**.

Use the **UP/DOWN ARROWS** to select the unit of measure desired; knots (KNOTS), miles per hour (MPH), or kilometers per hour (KPH), then press **ENT**.

Default value:

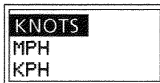

### Distance Units

Allows you to select the unit of measure for distance values.

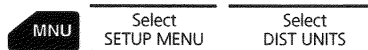

Press **MNU** and use the **UP/DOWN ARROWS** to highlight **SETUP** and press **ENT**. Use the **UP/DOWN ARROWS** to highlight **DIST UNITS** and press **ENT**.

Use the **UP/DOWN ARROWS** to select the unit of measure desired; nautical miles (NAUT MILES), statute miles (ST MILES), or kilometers (KM), then press **ENT**.

Default value:



### Elevation Units

Allows you to select the unit of measure for displaying elevation values.

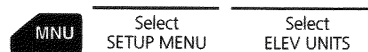

Press **MNU** and use the **UP/DOWN ARROWS** to highlight **SETUP MENU** and press **ENT**. Use the **UP/DOWN ARROWS** to highlight **ELEV UNITS** and press **ENT**.

Use the **UP/DOWN ARROWS** to select the unit of measure desired; METERS or FEET and then press **ENT**.

Default value:

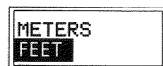



## North Reference

Allows you to select the value of north (magnetic or true) that the receiver will use to compute bearing and heading measurements.



Press **MNU** and use the **UP/DOWN ARROWS** to highlight SETUP MENU and press **ENT**. Use the **UP/DOWN ARROWS** to highlight NORTH REF and press **ENT**.

Use the **UP/DOWN ARROWS** to select TRUE or MAGNETIC and press **ENT**.

Default value:



## Map Datum

Allows you to change the datum the receiver uses to compute position coordinates to match the datum used on a map or chart. Use the map "legend" to determine the datum required for the map or chart. If unsure, select WGS84.

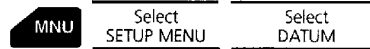

Press **MNU** and use the **UP/DOWN ARROWS** to highlight SETUP MENU and press **ENT**. Use the **UP/DOWN** or **LEFT/RIGHT ARROWS** to highlight MAP DATUM and press **ENT**.

Use the **UP/DOWN ARROWS** to select the datum you wish, then press **ENT**.

Default value:



See appendix for a complete list of available datums.

## NMEA

Your GPS 3000 can be set to output GPS data in the NMEA 0183 format to interface with other marine devices and PCs.

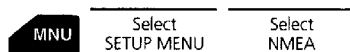

Press **MNU** and use the **UP/DOWN ARROWS** to highlight SETUP MENU and press **ENT**. Use the **UP/DOWN ARROWS** to scroll to the second page. Highlight NMEA and press **ENT**.

Use the **UP/DOWN ARROWS** to select the NMEA format you wish, then press **ENT**.

Consult your autopilot, plotter or radar manual for instructions on how to connect to the GPS 3000 correctly, and to see what message format is appropriate. The GPS 3000 supports the NMEA 0183 format and Magellan offers three output message sets: 0183A, 0183B, 0183C. (See appendix)

**Default value:**

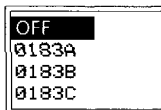

Optional Power/Data/Module or Power/Data/Antenna module required to output NMEA data.

## Baud Rate

The GPS 3000 offers a choice of baud rates for NMEA output or DGPS inputs. Check the documentation for your external equipment to select the appropriate baud rate.

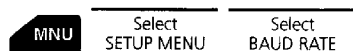

Press **MNU** and use the **UP/DOWN ARROWS** to highlight SETUP MENU and press **ENT**. Use the **UP/DOWN ARROWS** to scroll to the second page. Highlight BAUD RATE and press **ENT**.

Use the **UP/DOWN ARROWS** to select the desired baud rate, then press **ENT**.

**Default value:**

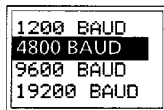



# Reference

Magellan GPS 3000

## Waypoint Sort

Waypoint sort classifies the waypoints stored in the user waypoint catalog in alphabetical order or according to their proximity to the present position with the closest listed first.



Press **MNU** and use the **UP/DOWN ARROWS** to highlight SETUP MENU and press **ENT**. Use the **UP/DOWN ARROWS** to scroll to the second page. Highlight WPT SORT and press **ENT**.

Use the **UP/DOWN ARROWS** to select ALPHABETIC or NEAREST, then press **ENT**.

Default value:



## Plot Setup

Plot Setup allows you to adjust the track orientation and track history on the Plotter screen.

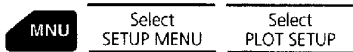

Press **MNU** and use the **UP/DOWN ARROWS** to highlight SETUP MENU and press **ENT**. Use the **UP/DOWN ARROWS** to scroll to the second page. Highlight PLOT SETUP and press **ENT**.

Use the **UP/DOWN ARROWS** to select PLOT ORIENT or TRACK HIST, then press **ENT**.

If you selected PLOT ORIENT, you are given a choice of the orientation of the plotter screen, North up or Track up.

Default value:



If you selected TRACK HIST, you are given a choice of settings for the distances units used to represent the distance between points taken to plot the track history.

The track history creates a dot each time you cover the selected distance, displaying up to 48 connected dots, and then begins erasing the points first created.

Default value:

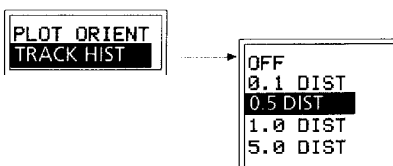

## Contrast

Used to adjust the contrast of the display.

Method 1:

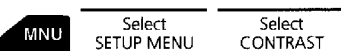

Press **MNU** and use the **UP/DOWN ARROWS** to highlight SETUP MENU and press **ENT**. Use the **UP/DOWN ARROWS** to scroll to the second page. Highlight CONTRAST and press **ENT**.

Method 2:

From any NAV screen, press **ENT** and select CONTRAST.

Then use the **RIGHT/LEFT ARROWS** to adjust the contrast and press **ENT**.

## SAT STATUS

### Viewing the SAT STATUS Screen

This screen provides you with the signal strength of each satellite being tracked and its relative position in the sky.

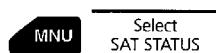

Press **MNU**, highlight SAT STATUS, and press **ENT** to display the SAT STATUS screen.

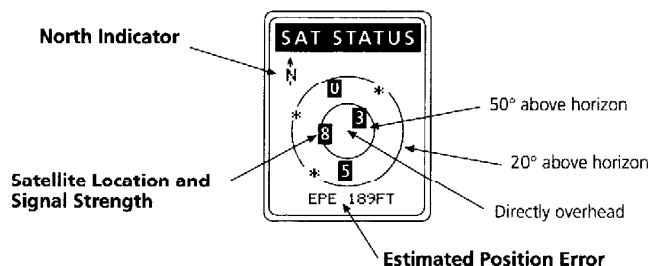



# Reference

Magellan GPS 3000

- \* Signal not being received
- 0-2 Weak signal strength.
- 3-6 Average signal strength.
- 7-9 Strong signal. Provides best possible signal strength for position fixes.

## SIMULATOR

The Simulate Mode allows you to view the navigation displays with an "active" route, and then practice entering waypoints and modifying your route. The receiver must be initialized to access this feature.



Press **MNU** and use the **UP/DOWN ARROWS** to highlight SIMULATOR and press **ENT**.

The message "ACTIVATED PRESS NAV KEY" appears.

Press **NAV** to return to the POSITION screen. The receiver begins navigating, using your initial position fix to project waypoints and create a multileg route appearing as ROUTE 5 in the route menu.

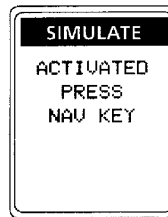

If all routes are full when SIMULATE is selected, SIMULATE will automatically use the user-defined route located in Route 5.

To Deactivate Simulator, follow the same steps: press **MNU** and use the **UP/DOWN ARROWS** to highlight SIMULATOR and press **ENT**.

The message "DEACTIVATED CHK INITIAL POSITION" appears.

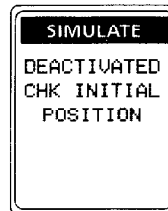

When SIMULATOR is deactivated, the temporary route it created is automatically deleted from the route menu. If a user defined route was used, it will remain intact.



During the simulation, the GPS 3000 position will change as the unit navigates toward waypoints on the simulated course. After deactivating SIMULATE, be sure to obtain a new position fix before using the receiver for position or navigation information.



## Troubleshooting

The following is a brief guide to some of the problems that might be encountered while using a GPS satellite receiver and what you can do to correct them.

### ***Receiver will not turn on***

- 1 Check to see if the batteries are installed correctly (p. 5).
- 2 Replace the batteries with four new alkaline AA batteries.
- 3 Press power key and hold for 5 seconds.

### ***Receiver will not compute a position fix or is losing lock (lock icon is open)***

- 1 Make sure that you have a clear and unobstructed view of the sky and that your hand and other items are not covering the antenna. Hold the receiver at a comfortable arm's length away from you body so that your body doesn't act as a shield to the signals from the satellites.
- 2 Have you moved over 300 miles with the receiver off since your last position fix? If so, the receiver may need to be reinitialized.
- 3 Check Sat Status to see where the satellites are and if the receiver is acquiring data.
- 4 Check date and time.

### ***GQ icon (▲) is displayed.***

- 1 Make sure that you have a clear and unobstructed view of the sky and that your hand and other items are not covering the antenna. Hold the receiver at a comfortable arms length away from you body so that your body doesn't act as a shield to the signals from the satellites.
- 3 Check Sat Status to see where the satellites are and if the receiver is acquiring data.

### ***Elevation jumps up and down***

- 1 Errors induced by the Department of Defense called Selective Availability (SA) can cause the elevation values to fluctuate.

### ***Battery life seems shorter than it should be***

- 1 Make sure that you are using quality AA Alkaline batteries. Magellan System recommends Eveready Energizers™ for use in the GPS 3000.
- 2 Shorter life spans of the batteries can be due to excessive use of the backlight. *Turn the backlight off when not needed.*



# Appendix

## Icons

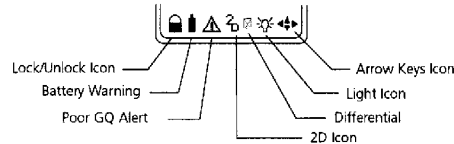
The bottom row of the display has been reserved for displaying icons that assist you in determining the operating status of the GPS 3000.



**Lock/Unlock Icon.** Provides a visual indication of whether the receiver is "locked" or "unlocked" on satellite signals.

-  GPS 3000 is locked onto satellite signals; computing fixes.
-  (blinking) GPS 3000 has low signal strength on the satellites it is tracking. Move the receiver so that it has a better view of the sky.
-  GPS 3000 is not locked onto enough satellites to compute a fix. Move the receiver so that it has a better view of the sky. (Also appears in SIMULATE mode.)

**Battery Warning.** When this icon first appears, the receiver will operate for an additional 30 minutes before automatically turning off.

**NOTE:** The GPS 3000 will retain its memory (route, waypoints, last fixes, etc.) for a minimum of 20 minutes with the batteries removed. Memory will be retained with low batteries for approximately one month if the unit is turned off.

**Poor GQ Alert.** When this icon appears, the geometric quality (GQ) of the satellites is poor. Try to move away from any large obstructions that may be blocking reception of satellite signals.

**2D Icon.** Is displayed when the receiver is in 2D mode and has computed a position fix. Also displayed when in 3D mode and there are not enough satellites to compute a 3D position fix.

**Light Icon.** Is displayed when the LCD backlight has been turned on with the **LIGHT** key. The backlight will cause the batteries to run down much quicker and should be turned off when not needed.

**Differential.** Indicates that the receiver is utilizing DGPS to compute position. (See appendix)

**Arrow Key Icon.** Provides a visual indication as to which arrow keys are active for the displayed screen.

## WARNINGS AND OTHER MESSAGES

DUPLICATE  
WAYPOINT  
NAME

You have attempted to assign a waypoint name that has already been used. Every waypoint must have a unique name.

Press **CLR** and assign a different name to the waypoint.

NO FIXES  
SAVED

You have attempted to view the Last Fix List without having any fixes in the last fix buffer.

Press **NAV** and position the receiver to collect satellite signals to compute a position fix. The receiver will create a last fix after a position fix is computed and will continue to create a last fix every 10 minutes thereafter.

MORE FIXES  
NEEDED TO  
CONTINUE

You have attempted to set a GOTO Backtrack without a sufficient number of last fixes to create the backtrack.

Position the receiver to collect satellite signals to compute a fixes. The receiver will create a last fix after a position fix is computed and will continue to create a last fix every 10 minutes thereafter.

WAYPOINT  
USED IN A  
ROUTE OR  
GOTO

You have tried to clear a waypoint that is currently used in a route, or a waypoint that is the destination of your current GOTO.

If the waypoint is in a route, clear the route from the Route Menu. If the waypoint is the destination of a GOTO route, select a new GOTO route.





## Appendix

Magellan GPS 3000



You have tried to view the SAT STATUS screen when the receiver has not been initialized.

Refer to the section on *Initializing the Receiver* and enter your initial coordinates.



You have tried to set a GOTO or Backtrack route without enough empty spaces in the waypoint list to create the temporary waypoints that GOTO and Backtrack require.

Access the Waypoint List from the MNU key. Select waypoints that you no longer need and clear them from memory. If you were trying to set a GOTO route, you will need to clear only one waypoint. For a Backtrack, you may have to clear several waypoints to create enough space for the Backtrack temporary waypoints.

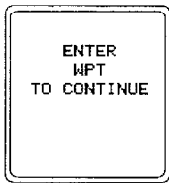

You have attempted to set a Route without having saved any waypoints. Enter waypoints to continue.



## **MAGELLAN GPS 3000 SWIVEL MOUNTING BRACKET**

### **Contents**

The Magellan GPS 3000 Swivel Mounting Bracket comes with the following parts:

- Holding cradle
- Rectangular mounting plate
- 2 1/4" Swivel screw
- Round swivel base
- 1" Swivel base nut

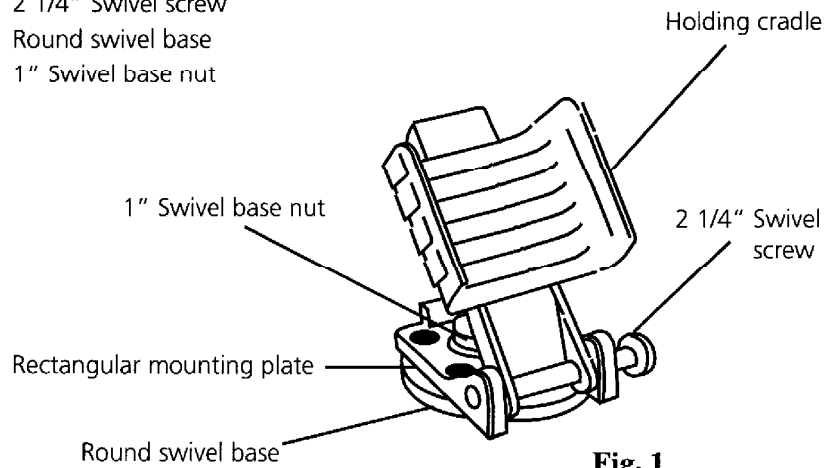

**Fig. 1**

### **To install on a dash board or other horizontal surface**

Secure the round swivel base to the dash board or other surface using the four screw holes.

Attach the rectangular mounting plate to the round swivel base using the 1" swivel base nut through the center holes of both pieces.

Adjust the ground nut to allow or restrict swivel movement, as desired.

Attach the holding cradle to the mounting plate by aligning the swivel screw holes of the holding cradle between those of the mounting plate. Apply gentle pressure to snap into place, and insert the 2 1/4" swivel screw from right to left. (Fig. 1)

**To install as a wall-mount:**

Secure the rectangular mounting plate to the wall using the four screw holes, with the tab facing upwards and the two swivel screw holes downwards.

Attach the holding cradle to the mounting plate by inserting the tab of the mounting plate into the slot on the back of the holding cradle.

Gently force the bottom portion into place to align the swivel screw holes of the holding cradle with those of the mounting plate, then insert the swivel screw from right to left.

NOTE : When the unit is installed on a wall or bicycle, the round swivel base and 1" swivel base nut are not used. Store in box for future use. (Fig. 2)

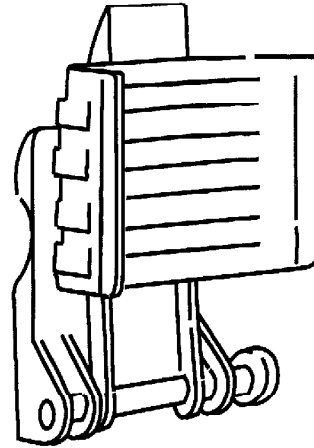

Fig. 2

**To install on bicycle handlebars:**

Secure the rectangular mounting plate to a handlebar by placing the scalloped edges of its underside on the handlebar and attach using two U-bolts, 1 1/2" in diameter, in the holes provided.

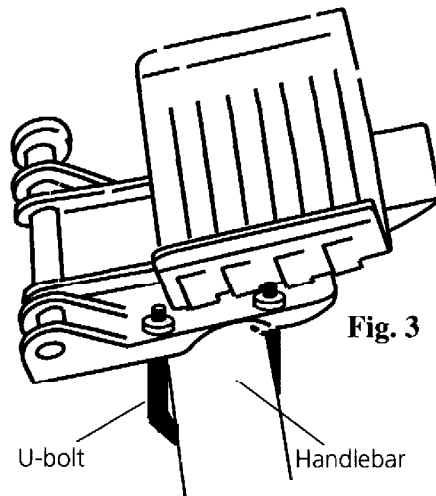

Fig. 3

Attach the holding cradle to the mounting plate by inserting the tab of the mounting plate into the slot on the back of the holding cradle.

Gently force the bottom portion into place to align the swivel screw holes of the holding cradle between those of the mounting plate, then insert the swivel screw. (Fig.3)

**The GPS 3000 can be snapped easily into and out of its holding cradle.**

When removing the unit from its cradle, simply pull the sides of the cradle gently apart and press fingers from behind until the unit is freed. (Fig. 4)

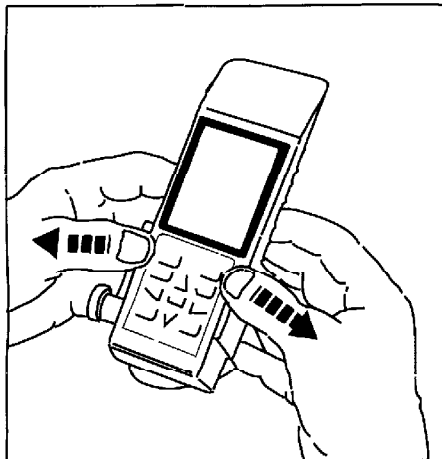

**Fig. 4**

### Listing of Available Datums

Datum	Full Name	Datum	Full Name
WGS84	World Geodetic System	INDIA	Indian (India, Nepal)
NAD27	North American 1927	IRAN	Iran
NAD83	North American 1983	IRELA	Ireland 1965
ADIND	Adinda	KAUAI	Kauai
ALASK	Alaska	KERTA	Kertau 1948
ARC50	Arc 1950	KKJ	KKJ (Finland)
ARC60	Arc 1960	LIBER	Liberia 1964
ASTRO	Camp Area Astro	LUZON	Luzon
AUS66	Australian Geodetic 1966	MASSA	Massawa
AUS84	Australian Geodetic 1984	MAUI	Maui
BOGOT	Bogota Observatory	MERCH	Merchich
BUKIT	Bukit Rimpah	MINNA	Minna
CAMPO	Campo Inchauspe	MONTJ	
CANAD	Canada	NAHRW	Nahrwan, Saudi Arabia
CAPE	Cape	OAHU	Oahu
CARTH	Carthage	OEGYP	Old Egyptian
CENAM	Central America	OHAWA	Old Hawaiian
CHATH	Chatham 1971	OMAN	Oman
CHUAA	Chau Astro	PITCA	Pitcairn Astro 1967
CORRE	Corrego Alegre	QATAR	Qatar National
CYPRU	Cyprus	QORNO	Qornoq
DJAKA	Djakarta (Batavia)	RT90	Rt90 (Sweden)
EGYPT	Egypt	SAM56	Provisional So. Am. 1956
EUROP	European 1950 (All of Europe)	SAM69	South American 1969
EUR50	European 1950 (W. Europe)	SCHWA	Schwarzeck
EUR79	European 1979	SICIL	Sicily
GANDA	Gandajika Base	SIERR	
GEO49	Geodetic Datum 1949	SWISS	
GHANA		TANAN	Tananarive Observatory 1925
GRB36	Ordnance Survey of GB, 1936	THAI	Indian (Thailand, Vietnam)
GUAM	Guam	TIMBA	Timbalai
GUNSG	G. Segara	TOKYO	Tokyo
GUNSR		USER DEFINED	
HAWAI	Hawaii	VOIRO	
HERAT	Herat North	WGS72	World Geodetic System 1972
HJORS	Hjorsey 1955	YACAR	Yacare
HUTZU	Hu-tzu-shan	ZANDE	Zanderij

## NMEA Attachment

### DATA TRANSFER

Your GPS receiver can be set to output GPS data in the NMEA 0183 format to interface with other marine devices.



The dataport must be turned on and the output message format selected in SETUP.

**NMEA DATA MESSAGES.** NMEA data is output at 4800 baud, 8, N, 1, checksum off. These settings are acceptable to most equipment and software applications.

There are several NMEA output message sets, each with a slightly different application. Check the documentation for your external equipment to select the appropriate message set.

SET OUTPUT/USAGE

0183A BWC, APA, GLL, VTG

Remote displays, version 1.x marine autopilots

0183B RMC, RMB

NMEA-recommended navigation data for remote map, etc.

0183C APB, GGA, BWC, GLL, VTG

Version 2.0 marine autopilot data and satellite data

#### NMEA Message Definitions

- APA Autopilot cross track error, direction to steer, status of GPS, route status, destination waypoint name, and bearing from origin to destination (old format).
- APB Revised autopilot message contains all of the above plus: heading to steer toward destination, bearing from the present position to the destination (magnetic or true).
- BWC Range and bearing to a waypoint
- GGA GPS position, time, fix quality, number of satellites used, HDOP (Horizontal Dilution of Precision), differential reference information, and age.
- GLL GPS-derived latitude, longitude, and time of fix.
- RMB Data status, cross track error, direction to steer, origin, destination waypoint, waypoint location, bearing to destination, and velocity toward the destination.
- RMC Time, latitude, longitude, speed over ground, course over ground, and date.
- VTG Track (magnetic and true) and groundspeed (knots and KPH).

Magellan GPS 3000

**OUTPUT DATA FORMAT****APA Autopilot Format A**

1 2 3 4 5 6 7 8 9 10  
 APA,A,A,X.XX,L,N,A,A,XXX.,M,CCC

- 1 OR'ed Blink and SNR (A = valid, V = invalid)
- 2 Cycle Lock (A = valid, V = invalid)
- 3-5 Cross Track, Sense (L = steer left, R = steer Right), N.Mi. Units
- 6-7 Arrival Circle, Arrival Perpendicular (crossing of the line which is perpendicular to the course line and which passes through the destination waypoint.
- 8-9 Bearing dest. wpt. from origin wpt., Magnetic
- 10 Dest wpt. identifier

**APB Autopilot Sentence "B"**

1 2 3 4 5 6 7 8 9 10 11 12 13 14  
 APB,A,A,x.x,a,N,A,A,x.x,a,c-c,x.x,a,x.x,a\*hh

- 1 Status: V = Loran-C Blink or SNR warning  
 A = general warning flag for other navigation systems when a reliable fix is not available.
- 2 Status: V = Loran-C cycle lock warning flag  
 A = OK or not used
- 3 Magnitude of XTE
- 4 Direction to steer (L, R)
- 5 XTE units, nautical miles
- 6 Status: A = arrival circle entered
- 7 Status: A = perpendicular passed at waypoint
- 8-9 Bearing origin to destination, M/T
- 10 Destination waypoint ID
- 11-12 Bearing, present position to destination, Magnetic or True
- 13-14 Heading to steer to destination waypoint, Magnetic or True

BWC To Selected Waypoint, Great Circle

1 2 3 4 5 6 7 8 9 10 11 12  
BWC, XXXXXX, XXXX.XX, N, XXXXX.XX, W, XXX., T, XXX., M, XXX.X, N, CCCC

- 1 UTC of Bearing
- 2-3 Lat. N or S of waypoint
- 4-5 Long, E or W of waypoint
- 6-7 Bearing, True
- 8-9 Bearing, Magnetic
- 10-11 Distance, naut. miles
- 12 Waypoint identifier

GGA Global Positioning System Fix Data

1 2 3 4 5 6 7 8 9 10 11  
GGA, hhhmss.ss, lll. ll, a, yyyyy.yy, a, x, xx, x.x, x.x, M, x.x,  
12 13 14  
M.x.x.xxxx\*hh

- 1 UTC of Position
- 2-3 Latitude - N/S
- 4-5 Longitude - E/W
- 6 GPS Quality Indicator
  - 0 = fix not available or invalid
  - 1 = GPS Fix
  - 2 = Differential GPS Fix
- 7 Number of satellites in use
- 8 Horizontal dilution of precision
- 9 Antenna altitude above/below mean sea level
- 10 Units of antenna altitude
- 11 Geoidal separation - difference between the WGS-84 earth ellipsoid and mean sea level (geoid). "-" = mean sea level below ellipsoid
- 12 Units of geoidal separation, meters.
- 13 Age of Differential GPS data - Time in seconds since last SC104 Type 1 or 9 update, null field when DGPS is not used
- 14 Differential reference station ID, 0000-1023



Magellan GPS 3000

GLL Geographic Position — Latitude/Longitude

1 2 3 4 5 6  
 GLL,1111.11,a,yyyy.yy,a,hmmss.ss,A\*hh

- 1-2 Latitude, N/S
- 2-3 Longitude, E/W
- 4 UTC of position
- 6 Status A = Data valid

RMB Generic Navigation Information (immediately follows RMC)

1 2 3 4 5 6 7 8 9 10 11 12  
 RMB,A,X.XX,L,CCCC,CCCC,SSS.SS,N,XXXXX.XX,W,XXX.X,XXX.X,XX.X,

13 14  
 A \*XX

- 1 Status (A = valid, V = invalid)
- 2-3 XTE, naut. miles and direction to steer (L or R) [If XTE exceeds 9.99 NM, display 9.99 in field 2.]
- 4 Origin waypoint ID
- 5 Destination waypoint ID
- 6-7 Destination Waypoint Latitude (N or S)
- 8-9 Destination Waypoint Longitude (E or W)
- 10 Range naut. miles, present fix to destination waypoint Great Circle. [If range exceeds 999.9 nm, display 999.9.]
- 11 Bearing, True, Great Circle, Present fix to dest. waypoint
- 12 Closing velocity to destination, knots
- 13 Arrival (OR'ed arrival circle and crossing of line which is perpendicular to the course line and which passes through the destination waypoint.)
- 14 CHECKSUM (Mandatory in this sentence.)

RMC Transit Specific (to be followed by RMB)

1 2 3 4 5 6 7 8 9 10  
12  
RMC,XXXXXX,A,XXXX.XX,N,XXXX.XX,W,XX.X,XXX.,XXXXXX,XX.,E  
\*XX

- 1 Time, UTC
- 2 Status (A = valid, V = invalid)
- 3-4 Latitude at UTC time, N or S
- 5-6 Longitude at UTC time, E or W
- 7 Speed over ground, knots
- 8 COG (track), degrees
- 9 Date (DDMMYY)
- 10 Variation, degrees
- 11 Variation, sense (E or W)
- 12 CHECKSUM (Mandatory in this sentence)

VTG Actual Track and Ground Speed (SOG)

1 2 3 4 5 6 7 8  
VTG,XXX.,T,XXX.,M,XX.X,N,XX.X,K  
1-2 Track degrees, True  
3-4 Track degrees, Magnetic  
5-6 Speed, knots  
7-8 Speed, kilometers/hour

The formats listed are NMEA formats and Magellan receivers may not output all of the information listed for a particular format.



## City Reference Chart

**Australia & SW Pacific**

Adelaide	34°55.00 S	138°35.00 E
Alice Springs	23°42.00 S	133°53.00 E
Apia	13°48.00 S	171°45.00 W
Auckland	36°55.00 S	174°47.00 E
Bourail	21°34.00 S	165°29.00 E
Brisbane	27°28.00 S	153°02.00 E
Canberra	35°17.00 S	149°08.00 E
Coober Pedy	28°56.00 S	134°45.00 E
Dampier	20°45.00 S	116°48.00 E
Darwin	12°28.00 S	130°50.00 E
Derby, WA	17°19.00 S	123°38.00 E
Honiara	9°28.00 S	159°57.00 E
Iron Range	12°39.00 S	143°13.00 E
Mount Isa	20°50.00 S	139°29.00 E
Nadi	17°47.00 S	177°29.00 E
Newman, Mt.	23°20.00 S	119°34.00 E
Ooldea	30°30.00 S	131°45.00 E
Perth	31°56.00 S	115°50.00 E
Port Moresby	9°30.00 S	147°07.00 E
Rawlinna	31°00.00 S	125°21.00 E
Timaru	44°23.00 S	171°14.00 E
Townsville	19°13.00 S	146°48.00 E

**Asia**

Bangalore	12°58.00 N	77°35.00 E
Bangkok	13°44.00 N	100°30.00 E
Beijing	39°55.00 N	116°26.00 E
Bombay	18°56.00 N	74°35.00 W
Calcutta	22°30.00 N	88°20.00 E
Colombo	6°55.00 N	79°52.00 E
Delhi	28°40.00 N	77°14.00 E
Hanoi	21°01.00 N	105°52.00 E
Harbin	45°45.00 N	126°41.00 E
Ho Chi Minh City	10°46.00 N	106°43.00 E
Hong Kong	22°15.00 N	114°10.00 E
Islambad	33°40.00 N	73°08.00 E
Jakarta	6°08.00 S	106°45.00 E
Kagoshima	31°37.00 N	130°32.00 E
Kandla	23°03.00 N	70°11.00 E
Karachi	24°51.00 N	67°02.00 E
Kathmandu	27°42.00 N	85°19.00 E
Kinabalu, Gunung	6°03.00 S	116°32.00 E
Kota, Malaysia	2°33.00 N	102°10.00 E
Kuala Lumpur	3°08.00 N	101°42.00 E
Kunming	25°04.00 N	102°41.00 E
Malang	7°59.00 S	112°45.00 E
Mandalay	21°57.00 N	96°04.00 E
Nagpur	21°10.00 N	79°12.00 E
Padang	6°12.00 S	120°27.00 E
Palu	8°19.00 S	121°44.00 E
Pinang	5°30.00 N	100°28.00 E
Pontianak	0°05.00 S	109°16.00 E
Rangoon	16°47.00 N	96°10.00 E
Sapporo	43°05.00 N	141°21.00 E
Seoul	37°30.00 N	127°00.00 E
Shanghai	31°06.00 N	121°22.00 E
Sorong	0°50.00 S	131°17.00 E
Surakarta	7°32.00 S	110°50.00 E
Tanahmerah	6°08.00 S	140°18.00 E
Taipei	25°05.00 N	121°32.00 E
Thimphu	27°32.00 N	89°43.00 E

Tokyo	35°40.00 N	139°45.00 E
Tonhil	46°19.00 N	93°54.00 E
Ulaanbaatar	47°54.00 N	106°52.00 E
Ürümqi	43°43.00 N	87°38.00 E
Wuhan	30°35.00 N	117°55.00 E
Xi'an	34°16.00 N	108°54.00 E
Yumen	39°54.00 N	97°43.00 E

**CIS**

Anadyr	64°50.00 N	177°50.00 E
Arkhangel'sk	64°32.00 N	40°40.00 E
Ashkhabad	37°58.00 N	58°24.00 E
Baku	40°22.00 N	49°53.00 E
Balkhash	46°50.00 N	74°57.00 E
Barnaul	53°21.00 N	83°45.00 E
Chita	52°03.00 N	113°35.00 E
Gizhiga	62°00.00 N	160°34.00 E
Igarka	67°31.00 N	86°33.00 E
Inarigda	63°15.00 N	107°40.00 E
Kargasok	59°07.00 N	80°58.00 E
Khatanga	71°59.00 N	102°31.00 E
Kiyev	50°25.00 N	133°43.00 E
Krasnodar	45°02.00 N	39°00.00 E
Magdagachi	53°27.00 N	125°44.00 E
Moscow	55°45.00 N	37°42.00 E
Okhotsk	59°20.00 N	143°15.00 E
Perm	58°01.00 N	56°10.00 E
Petropavlovsk	54°53.00 N	69°13.00 E
Riga	56°40.00 N	106°10.00 E
Saratov	51°30.00 N	45°55.00 E
Tashkent	41°16.00 N	69°13.00 E
Tulun	54°32.00 N	100°35.00 E
Vanino	49°05.00 N	140°14.00 E
Vladivostok	43°09.00 N	131°53.00 E
Vorkuta	67°27.00 N	64°00.00 E
Yakutsk	62°10.00 N	129°50.00 E

**Middle East**

Al Kuwait	29°20.00 N	48°00.00 E
Ar Riyad	24°39.00 N	46°46.00 E
Baghdad	33°20.00 N	44°26.00 E
Bam	36°57.00 N	57°56.00 E
Halab	36°14.00 N	37°10.00 E
Herat	34°20.00 N	62°12.00 E
Jerusalem	31°47.00 N	35°13.00 E
Kabul, Afghanistan	34°31.00 N	69°12.00 E
Mashhad, Iran	36°16.00 N	59°34.00 E
Nazwa	22°56.00 N	57°33.00 E
Salalah	17°00.00 N	54°04.00 E
San' a	15°24.00 N	44°14.00 E
Shiraz	29°38.00 N	52°34.00 E
Tabriz	38°05.00 N	46°18.00 E
Tarim	16°08.00 N	48°58.00 E
Tehran	35°40.00 N	51°26.00 E

**Africa**

Abidjan	5°19.00 N	0°05.00 W
Ad Dakhla	23°43.00 N	15°57.00 W
Adis Abeba	9°03.00 N	38°42.00 E
Alger	36°50.00 N	3°00.00 E
Antananarivo	18°52.00 S	47°30.00 E
Asmera	15°20.00 N	38°58.00 E
Aswan	24°05.00 N	32°56.00 E

# Appendix

## Magellan GPS 3000

Bamako	12°39.00 N	8°00.00 W	Nice	43°42.00 N	7°15.00 E
Banghazi	32°07.00 N	20°04.00 E	Nuugaatsiaq	71°30.00 N	53°00.00 W
Bangui	4°22.00 N	18°35.00 E	Oslo	59°55.00 N	10°45.00 E
Beira	19°49.00 S	34°52.00 E	Paris	48°52.00 N	2°20.00 E
Cairo	30°03.00 N	31°15.00 E	Reykjavik	64°09.00 N	21°51.00 W
Capetown	33°55.00 S	18°22.00 E	Scoresbysund	70°30.00 N	22°00.00 W
Dakar	14°40.00 N	17°26.00 W	Stensele	65°05.00 N	17°10.00 E
Fés	34°05.00 N	5°00.00 W	Stockholm	59°20.00 N	18°03.00 E
Freetown	8°30.00 N	13°15.00 W	Thule	76°35.00 N	68°30.00 W
Harare	17°50.00 S	31°03.00 E	Torshavn	62°02.00 N	6°47.00 W
Kabwe	14°29.00 S	28°25.00 E	Trabzon	41°00.00 N	39°43.00 E
Kampala	0°19.00 N	32°25.00 E	Vardo	60°16.00 N	20°20.00 E
Kano	12°00.00 N	8°31.00 E			
Khartoum	15°36.00 N	32°37.00 E	<b>The Americas</b>		
Kinshasa	4°18.00 S	15°18.00 E	Albany, NY	42°39.00 N	73°45.00 W
Kisangani	0°33.00 N	25°14.00 E	Albuquerque	35°05.00 N	106°39.00 W
Lagos	6°27.00 N	3°24.00 E	Amarillo	35°14.00 N	101°50.00 W
Las Palmas de GC	28°08.00 N	15°27.00 W	Antofagasta	23°40.00 S	70°23.00 W
Lindi	10°00.00 S	39°41.00 E	Arequipa	16°25.00 S	71°32.00 W
Lobito	12°20.00 S	13°34.00 E	Atlanta	33°44.00 N	84°23.00 W
Lomé	6°08.00 N	1°13.00 E	Baton Rouge	30°27.00 N	91°09.00 W
Lubumbashi	11°41.00 S	27°29.00 E	Belem	1°27.00 S	48°29.00 W
Lüderitz	26°38.00 S	15°10.00 E	Billings, MT	45°47.00 N	108°30.00 W
Lusambo	4°59.00 S	23°26.00 E	Birmingham	33°31.00 N	86°48.00 W
Maputo	25°58.00 S	32°35.00 E	Bismarck	46°48.00 N	100°47.00 W
Maseru	29°19.00 S	27°29.00 E	Bogotá	4°36.00 N	74°05.00 W
Mbale	1°04.00 N	34°12.00 E	Boise	43°36.00 N	116°12.00 W
Mogadishu	2°02.00 N	45°21.00 E	Boston	42°21.00 N	71°03.00 W
Monrovia	6°18.00 N	10°47.00 W	Brasilia	15°47.00 S	47°55.00 W
Mwanza, Zaire	7°51.00 S	26°43.00 E	Buffalo, NY	42°52.00 N	78°55.00 W
N' Djamena	12°10.00 N	14°59.00 E	Caracas	10°30.00 N	66°56.00 W
Nairobi	1°17.00 S	36°49.00 E	Casper	42°50.00 N	106°20.00 W
Namibe	15°10.00 S	12°09.00 E	Cayenne	4°56.00 N	52°20.00 W
Nouakchott	18°09.00 N	15°58.00 W	Chicago	41°51.00 N	87°39.00 W
Ouagadougou	12°22.00 N	1°31.00 W	Chihuahua	28°40.00 N	106°06.00 W
Pointe Noire	4°46.00 S	11°53.00 E	Churchill, CAN	58°45.00 N	94°00.00 W
Port Elizabeth	33°58.00 S	25°36.00 E	Cleveland	41°29.00 N	81°41.00 W
Sabha, Libya	27°02.00 N	14°26.00 E	Comodoro R	45°50.00 S	67°30.00 W
Serowe	22°25.00 S	26°44.00 E	Coppermine	67°49.00 N	115°21.00 W
Sidi Ifni	29°24.00 N	10°12.00 W	Córdoba, Veracruz	18°55.00 N	96°55.00 W
Toliara	23°20.00 S	43°41.00 E	Cuiabá	7°15.00 S	58°25.00 W
Tombouctou	16°49.00 N	2°59.00 W	Dallas	32°46.00 N	96°47.00 W
Tripoli	32°54.00 N	13°11.00 E	Denver	39°44.00 N	104°59.00 W
Tsumeb	19°13.00 S	17°42.00 E	Des Moines	41°36.00 N	93°36.00 W
Tunis	36°48.00 N	10°11.00 E	Detroit	42°20.00 N	83°03.00 W
Winhoek	22°34.00 S	17°06.00 E	Duluth	46°45.00 N	92°10.00 W
Yaounde	3°52.00 N	11°31.00 E	Fort McPherson	67°29.00 N	134°50.00 W
Zanzibar	6°10.00 S	39°20.00 E	Fort Providence	61°03.00 N	117°40.00 W
			Georgetown, Guy.	6°48.00 N	58°10.00 W
<b>Europe</b>			Grand Rapids, MI	42°57.00 N	86°40.00 W
Athens	37°58.00 N	23°43.00 E	Guadalajara	20°40.00 N	103°20.00 W
Barcelona	41°23.00 N	2°11.00 E	Guantánamo	20°09.00 N	75°14.00 W
Bern	46°57.00 N	7°26.00 E	Guatemala	14°38.00 N	90°31.00 W
Bordeaux	44°50.00 N	0°34.00 W	Guayaquil	2°10.00 S	79°50.00 W
Brno	49°13.00 N	16°40.00 E	Hazelton, BC	55°15.00 N	127°38.00 W
Bucuresti	44°26.00 N	26°06.00 E	Houston	29°45.00 N	95°21.00 W
Budapest	47°30.00 N	19°05.00 E	Ilhéus	14°50.00 S	39°06.00 W
Cork	51°54.00 N	8°28.00 W	Indianapolis	39°46.00 N	86°09.00 W
Gdansk	54°23.00 N	18°40.00 E	Iquitos	3°51.00 S	73°13.00 W
Glasgow	55°53.00 N	4°15.00 W	Kansas City, MO	39°02.00 N	94°33.00 W
Godthåb	64°11.00 N	51°44.00 W	La Habana	23°08.00 N	82°22.00 W
Hamburg	53°33.00 N	9°59.00 E	Labrador City	52°56.00 N	66°52.00 W
Istanbul	41°01.00 N	28°58.00 E	Las Vegas	36°10.00 N	115°08.00 W
London	51°30.00 N	0°10.00 W	Lima	12°03.00 S	77°03.00 W
Longyearbyen	78°12.00 N	15°40.00 E	Little Rock	34°44.00 N	92°17.00 W
Madrid	40°24.00 N	3°41.00 W	Los Angeles	34°03.00 N	118°14.00 W
Napoli	40°51.00 N	14°17.00 E	Louisville	38°15.00 N	85°45.00 W



## Appendix

### Magellan GPS 3000

Managua	12°06.00 N	86°18.00 W	São Paulo	23°32.00 S	46°37.00 W
Manaus	3°06.00 S	60°00.00 W	Saskatoon	52°10.00 N	101°32.00 W
Merida, Venezuela	8°24.00 N	71°08.00 W	Seattle	47°36.00 N	122°19.00 W
Miami	25°46.00 N	80°11.00 W	Shreveport	32°30.00 N	93°46.00 W
Milwaukee	43°02.00 N	87°54.00 W	Sioux Falls	43°34.00 N	96°42.00 W
Minneapolis	44°58.00 N	93°15.00 W	Spokane	47°40.00 N	117°25.00 W
Montevideo, Uru.	34°53.00 S	56°11.00 W	St Louis	38°37.00 N	90°11.00 W
Nakina	59°12.00 N	132°48.00 W	Tampa, FL	27°58.00 N	82°38.00 W
Nashville, TN	36°09.00 N	86°47.00 W	Tijuana	32°32.00 N	117°01.00 W
New York	40°43.00 N	74°01.00 W	Toronto	43°39.00 N	79°23.00 W
Norfolk, VA	36°50.00 N	76°17.00 W	Valparaiso, Brazil	21°16.00 S	50°54.00 W
Oklahoma City	35°28.00 N	97°30.00 W	Vancouver	49°16.00 N	123°07.00 W
Omaha	41°15.00 N	95°56.00 W	Veracruz	19°12.00 N	96°08.00 W
Panama City	8°58.00 N	79°32.00 W	Washington	38°53.00 N	77°02.00 W
Peace River	56°15.00 N	117°18.00 W	Whitehorse	60°43.00 N	135°03.00 W
Peoria, IL	40°43.00 N	89°38.00 W	Wichita	37°43.00 N	97°20.00 W
Phoenix	33°26.00 N	112°04.00 W	Winnipeg	49°53.00 N	97°09.00 W
Pittsburgh	40°26.00 N	79°59.00 W			
Port-au-Prince	18°32.00 N	72°20.00 W	<b>Pacific Ocean</b>		
Portland, OR	45°31.00 N	122°40.00 W	American Samoa	14°20.00 S	170°00.00 W
Porto Velho	8°45.00 S	63°54.00 W	Baker I.	0°12.00 N	176°28.00 W
Québec	46°50.00 N	71°15.00 W	Easter I.	27°05.00 S	109°20.00 W
Rapid City, SD	44°06.00 N	103°14.00 W	Gambier I.	23°10.00 S	135°00.00 W
Recife	8°06.00 S	34°53.00 W	Honolulu	21°18.00 N	157°51.00 W
Reno	39°32.00 N	119°49.00 W	Howland I.	0°48.00 N	176°38.00 W
Rio de Janeiro	22°54.00 S	43°14.00 W	Jarvis I.	0°02.00 S	160°02.00 W
Salt Lake City	40°45.00 N	111°53.00 W	Kanton I.	2°50.00 S	171°40.00 W
San Antonio	29°25.00 N	98°29.00 W	Lihue	21°59.00 N	159°23.00 W
San Francisco	37°46.00 N	122°25.00 W	Palmyra I.	5°52.00 N	162°05.00 W
San Juan	18°28.00 N	66°07.00 W	Pitcairn I.	25°04.00 S	130°06.00 W
Santarém	2°26.00 S	54°41.00 W	Swains I.	59°30.00 S	100°00 W



## Abbreviations

°M	Degrees Magnetic north	MNU	MENU
°T	Degrees True north	MPH	Miles per hour
2D	Two-dimensional	NAV	NAVIGATE
3D	Three-dimensional	NM	Nautical mile
BRG	Bearing	POS	Receiver-generated name for current position
CDI	Course Deviation Indicator	SA	Selective Availability
CLR	CLEAR	SEC	Seconds
COG	Course over ground	SOG	Speed over ground
CTS	Course to steer	SPD	Speed
DEG	Degrees	START	Receiver-generated name for first waypoint in a route
DST	Distance	TTG	Time To Go
ENT	ENTER	UTM	Universal Transverse Mercator
FT	Feet	UT	Universal Time
GPS	Global Positioning System	VMG	Velocity made good
GQ	Geometric Quality	WPT	Receiver-generated waypoint name
HDG	Heading	XTE	Cross track error
KM	Kilometers		
KH	Kilometers per hour		
KPH	Kilometers per hour		
KT	Knots		
LAT	Latitude		
LFIX	Last Fix		
WPT	Waypoint		
LON	Longitude		
M	Meters		
MH	Miles per hour		
MI	Miles		
MIN	Minutes		

## Specifications

### CHARACTERISTICS

#### Performance

Receiver	AllView 12 Technology, tracks up to 12 satellites to compute and update position information
Acquisition Times (under optimal conditions):	
Warm	Approx 35 seconds
Cold	Approx. 2.5 minutes
Update Rate	1 second continuous
Accuracy:	
Position	49 feet (15 meters) RMS (without Selective Availability) Better accuracy requires DGPS.
Velocity	0.1 knot RMS steady state (with Selective Availability turned off).

#### Physical

Size	6.6" x 2.3" x 1.3" [h] x [w] x [d] 16.7 cm x 5.8 cm x 3.3 cm
Weight	10 ounces (283 grams) with 4 AA batteries installed
Display	1.8" x 1.4" [h] x [w] 4.6 cm x 3.6 cm high contrast LCD with backlighting
Housing	Waterproof construction
Temp. Range:	
Operating	14°F to 140°F (-10°C to 60°C)
Storage	-40°F to 167°F (-40°C to 75°C)

#### Power

Source	4 AA alkaline batteries or 10–16 VDC with optional external power/data module
Battery Life	17 hours continuous operation
Current Drain	80 mA without light, 145 mA with light

## What is GPS?

### WHAT IS GPS?

GPS is a constellation of navigation satellites that orbit the earth. The precise time and position information transmitted by these satellites is used by a GPS receiver to compute a position fix.

The system is now officially declared "operational," and provides continuous, 24-hour 3D (position plus elevation) coverage anywhere on the earth.

GPS was developed by the United States Department of Defense to provide consistent, reliable navigation information that is unaffected by rough terrain and bad weather, and is highly resistant to multipath errors and interference. The DoD continues to administer and control the Global Positioning System.

Although GPS was developed as a military navigation system, its civilian and commercial uses were recognized. The satellites therefore transmit two codes, a military-only encrypted code (PPS) and a civilian-access, Standard Positioning Service (SPS) code. All commercial and consumer GPS receivers are SPS receivers.

### HOW DOES GPS WORK?

Each GPS satellite transmits its precise location (position and elevation) and the start time of the transmission. A GPS receiver acquires the signal, then measures the interval between transmission and receipt of the signal to determine the distance between the receiver and the satellite: this is ranging. Once the receiver has computed range for at least three satellites, its location on the surface of the earth can be determined.

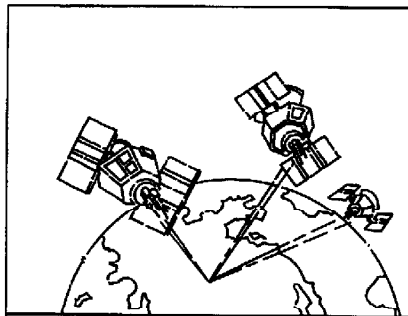

Every satellite transmits two types of data, almanac and ephemeris. Almanac data is general information on the location and health of each satellite in the constellation. Since it contains general information, an almanac can be collected from any satellite. A receiver with a current almanac in its memory knows where in the sky to look

for satellites, given its last known position and the time of day. Ephemeris data is the precise satellite positioning information that is used for ranging. Each satellite transmits its own ephemeris data.



Both almanac and ephemeris data are required for a GPS receiver to locate and acquire satellites quickly and compute a position fix. Your Magellan receiver copies these messages automatically.

### ACCURACY

GPS positioning with an SPS receiver that is intended for general use will produce an accuracy of 25 meters or better.

In fact, SPS receivers have proven to be far more accurate than anyone anticipated. DoD has decided that 25-meter accuracy is a potential risk, and has introduced Selective Availability (SA) to maintain a military advantage. SA is a random error that is introduced to the SPS code ephemeris and timing data and reduces the accuracy of any SPS receiver. The size of the error changes, but rarely exceeds 100 meters.

The DoD civil GPS user policy is that GPS accuracy as affected by SA is sufficient for general navigation. In an open environment, it usually is. Even with SA, a GPS receiver will bring you within visual range of a destination or target, and GPS remains the best available source of accurate, reliable navigation and positioning information.

If you feel that you really need 25-meter accuracy, the effects of SA can be overcome with a technique called broadcast differential to produce highly accurate position fixes.

### DGPS

Differential GPS (DGPS) computes the size of the error and applies it to positioning information. There are several ways to perform DGPS, one of which is broadcast differential. Broadcast differential uses GPS receivers at control sites to measure the range errors for all visible satellites and determines a correction for each satellite. These corrections are broadcast in the RTCM SC-104 format by a radio beacon at the control site to any differential beacon receiver that is within range of the signal.

The differential beacon receiver receives and demodulates the signal, then relays it to the user's differential-ready GPS receiver. The user's GPS receiver applies the corrections to the positioning information it collects to compute differentially corrected position and navigation data.

This technique requires that your GPS receiver be connected to a compatible differential beacon receiver (such as the Magellan DBR™, which is compatible with all differential-ready Magellan receivers). You must also be within range of a differential radio beacon.

## Where to Get More Information on GPS

There are many sources for more information on GPS and navigation. The sources listed here are just a few of the books, magazines, and Internet addresses that deal with GPS. Your local library is a good source for technical books on GPS and navigation.

### **GPS Information Center**

The GPS Information Center provides general information on the Global Positioning System and satellite status. This center is operated by U.S. Coast Guard for the Department of Transportation, and was established to provide information and to serve as a point of contact for civilian GPS users.

- Voice telephone recording for constellation status. (703) 313-5907
- Computer bulletin board: (703) 313-5910 (up to 14,400 bps) (8 data bits, 1 stop bit, no parity)
- 24 hour operator: (703) 313-5900; fax: (703) 313-5920

### **A Comprehensive Guide to Land Navigation with GPS**

An excellent book written by Noel J. Hotchkiss and published by Alexis Publishing. ISBN No: 0-9641273-2-6. This book uses the Magellan Trailblazer to discuss and describe land navigation with a GPS receiver. The book is very easy to read and gets into detail the art of navigating with GPS. (Available from Navtech Seminars.)

### **Newsgroups (Internet)**

Several USENET newsgroups have occasional postings related to GPS. Some of the more popular newsgroups for GPS are:

- sci.geo.satellite-nav
- rec.aviation.products
- rec.boats
- sci.space
- sci.space.news

### GPS World Magazine

Monthly magazine covering a wide variety of uses for GPS receivers.

Advanstar Communications  
859 Willamette Street  
Eugene, Oregon 97401  
U.S.A.  
Phone: (503) 343-1200  
Subscriptions: 1-800-346-0085 x363

### Other Books of Note:

Hofmann-Wellenhof, B., H. Lichtenegger, and J. Collins (1994). Global Positioning System, Theory and Practice. 3rd Edition. Springer-Verlag, 326 pp.

Institute of Navigation, The (1980). Global Positioning System. Vol. I. The Institute of Navigation (U.S.), 246 pp.

Institute of Navigation, The (1984). Global Positioning System. Vol. II. The Institute of Navigation (U.S.), 257 pp.

Institute of Navigation, The (1986). Global Positioning System. Vol. III. The Institute of Navigation (U.S.), 293 pp.

Institute of Navigation, The (1986). Global Positioning System. Vol. IV. The Institute of Navigation (U.S.), 378 pp.

Logsdon, T. (1992). Navstar Global Positioning System. Van Nostrand Reinhold, New York, 249 pp.

These books and others not mentioned can be purchased from Navtech Book and Software Store (a division of Navtech Seminars, Inc.). They can be reached at:

2775 S. Quincy St. #610  
Arlington, VA 22206-2204  
U.S.A.  
Phone: (800) 628-0885  
(703) 931-0500  
Fax: (703) 931-0503

## Accessories

Accessories and replacement parts for the GPS 3000 receiver are available directly from Magellan Systems Corporation.

### ACCESSORIES FOR THE MAGELLAN GPS 3000

**External Power/Data Module.** Allows the GPS 3000 to be powered from 10–16 VDC and supports NMEA/DGPS devices.

**Power/Data/Antenna Module.** Allows the GPS 3000 to be powered from 10-16 VDC, support NMEA/DGPS devices and connect a low profile external antenna to the unit.

**Low Profile External Antenna.** Ceramic Planar Patch Antenna mounted under a plastic radome. Requires the Power/Data/Antenna Module.



**Power/Data/External Antenna Kit.** Includes the Power/Data/Antenna Module and the Low Profile External Antenna.

**Instructional Video. (VHS)**

The following is a listing of the accessories and replacement parts available. Please note that all prices are subject to change without notice.

### ACCESSORIES / REPLACEMENT PARTS

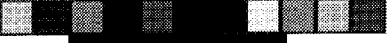
Part No.	Description	Price
00-69011-000	<i>Instructional Video</i>	\$ 14.95
00-69010-000	<i>Carrying Case</i>	\$9.99
00-68007-000	<i>External Power/Data Module</i>	\$49.99
00-19045-000	<i>Power/Data/Antenna Module</i>	\$69.99
00-19043-000	<i>Power/Data/External Antenna Kit</i>	\$149.99
00-19044-000	<i>Low Profile External Antenna</i>	\$95.00
00-69008-000	<i>Swivel Mounting Bracket</i>	\$19.99
22-10193-001	<i>GPS 3000 User Guide</i>	\$5.00
22-10205-000	<i>GPS 3000 Quick Reference Guide</i>	\$3.00



Magellan GPS 3000



*Appendix*

**Direct Order by Mail, Fax, or Phone**

**By Mail:** Complete the order form, adding shipping and handling charges, and sales tax where applicable. Include a check, money order or credit card information and send it to:

Magellan Systems Corporation  
Attention: Order Department  
960 Overland Court  
San Dimas, CA 91773-1742 USA

**By Fax:** Complete the order form, adding shipping and handling charges, and sales tax where applicable. Include your credit card information and fax the form to:

Magellan Systems Corporation  
(909) 394-7050



**By Phone:** Complete the order form, adding shipping and handling charges, and sales tax where applicable. Have the order form and your credit card information ready and phone the Magellan Systems Order Hotline. You can then place your order via voice mail. Please leave your phone number should we need to reach you concerning your order.



Magellan Systems Order Hotline  
(909) 394-6067

***Please allow 2 to 4 weeks for delivery.***

## Glossary

---

<b>Active Leg</b>	The segment of a route currently being travelled.
<b>Azimuth</b>	The angular measurement from the horizon to a satellite or other object.
<b>Backtrack</b>	Retraces the position fixes (up to 21) stored automatically by the GPS 3000 every 10 minutes.
<b>Bearing</b>	The compass direction from your position to a destination, measured to the nearest degree.
<b>Coordinates</b>	A unique numeric or alphanumeric description of position.
<b>Course</b>	The direction in degrees from the start waypoint of a course line to its destination.
<b>CTS</b>	The optimum direction the vessel should be steered in order to efficiently make headway back to the course line while also proceeding toward the destination waypoint. It is a "compromise" course bearing that projects from your current position to a point on the course line mid-way between a point perpendicular to your position and the current leg destination waypoint.
<b>Datum</b>	Refers to the theoretical mathematical model of the earth's sea level surface. Map makers may use a different model to chart their maps from so positions will differ from one datum to another. The datum for the map you are using can be found in the legend of the map.
<b>Elevation</b>	Distance above or below mean sea level.
<b>EPE</b>	Estimated Position Error is the approximate error (between 0 and X) introduced in the ephemeris signal by the U.S. Department of Defense for reasons of security. This random error, known as Selective Availability (SA) is <b>not</b> due to receiver error and is not significant enough to affect navigation for most purposes (See DGPS in appendix).
<b>Heading</b>	The direction in which the GPS 3000 is moving, track or ground course, (due to wind, current, and so forth), and may also be different from the course.
<b>Geometric Quality</b>	Measures the probable accuracy of a position fix, based on the position of the satellites relative to each other.



## Appendix

*Magellan GPS 3000*

- GOTO** A single leg route with the present position being the start of the route and a defined waypoint as the destination. (If the unit has been moved while turned off and has not yet acquired a new position fix, the start of the GOTO will be the position fix last recorded.)
- LAT/LON** Coordinate system using latitude and longitude coordinates to define a position on the earth.
- Latitude** The angular distance north or south of the equator measured by lines encircling the earth parallel to the equator in degrees from 0° to 90°.
- Last Fix** Position coordinates computed and stored automatically every 10 minutes in the Last Fix Buffer.
- Last Fix Buffer** The list of the most recent last fixes automatically stored by the GPS 3000. (Up to 21 may be stored at one time.)
- Leg (Route)** A segment of a route that has a starting (FROM) waypoint and a destination (TO) waypoint. A route may consist of 1 or more legs. For a route that is from waypoint A to waypoint B, waypoint B to waypoint C, and waypoint point C to waypoint D has three legs with the first leg being from waypoint A to waypoint B.
- Longitude** The angular distance east or west of the prime meridian (Greenwich meridian) as measured by lines perpendicular to the parallels and converging at the poles from 0° to 180°.
- Magnetic North** The direction toward the north magnetic pole from the observer's position.
- OSGB** A coordinate system describing only Great Britain, similar to UTM's. Generally used with GBR36 datum, which also describes only Great Britain. This coordinate system cannot be used in any other part of the world. The Meridian XL and NAV 1200 automatically selects the GBR36 datum when the OSGB coordinate system is selected in Setup. (While OSGB coordinates must be used with the GBR36 datum, the GBR36 datum can be used with LAT/LON coordinates; just be sure the map you are using uses both LAT/LON and GBR36.)
- Position Fix** Position coordinates as computed by the GPS 3000.
- Reverse Route** Duplicates an existing route but in reverse order.



- Route** A planned course of travel that is defined by a sequence of waypoints. When active, the route is used in the calculation of all navigation data except position, speed over ground and track/course over ground.
- Start and Destination Waypoint (FROM/TO)** Waypoints that mark the beginning and ending of a leg of a route.
- TDs** Coordinate system using lines of position determined by the Loran-C signals. Many coastal navigators use TDs because Loran is a familiar radio aid navigation and TDs are clearly marked on their charts. Your Magellan receiver can display position coordinates in TDs by converting from LAT/LON.
- Time To Go** The estimated time for the receiver to reach the destination from its current position based on the current VMG.
- True North** The direction to the geographical North Pole from an observer's position. The north direction on any geographical meridian.
- Track** The actual path travelled, which may differ from the planned course.
- Track History** The track over a selected length of time.
- UT** Universal Time, formerly referred to as Greenwich Mean Time (GMT).
- UTM** Universal Transverse Mercator (UTM) metric grid system used on most large and intermediate scale land topographic charts and maps.
- VMG** Velocity Made Good. The component of the velocity that is in the direction of the destination.
- Waypoint** A location saved in the unit's memory which is obtained by entering data, editing data, calculating data or saving a current position. Used to create routes



## INDEX

- Abbreviations 64
- Accuracy 67
- Accessories 70; order form
- Backtrack 20
- Batteries, installation 5
- CDI - Course Deviation Indicator 23
- City Reference Chart 61
- Clear Menu 37; clearing all last fixes 37, clearing track 38, clearing all waypoints 38, clearing all memory 38
- Contrast 12
- Coordinate System 40
- Datums 55
- Distance Units 42
- DGPS 67
- Elevation mode 40; units 42
- Getting started 4
- Glossary 72
- GOTO 10; activating 20; creating, 10
- Icons 49
- Initial Position Fix 5, 8
- Initialization 5
- Introduction 1
- Waypoints, creating, 9, 13; deleting 17; editing 14; saving a Position as a Waypoint 9, 13; viewing 17, projecting 16, waypoint sort 45
- Last Fix Buffer, deleting a (single) Last Fix 19; Clearing Last Fix Buffer 37; copying a last fix as a waypoint 19
- Leg (see Routes)
- Light 12
- Map Datum 42
- MNU 4
- MOB 20
- Navigation, screens 21; NAV1 screen 23, NAV2 screen 24
- NMEA 44, 56
- North Reference 43
- Odometer 36
- ON/OFF 11
- Pan n Scan 26
- Plotter 26
- Plot Setup 45
- Pointer 25
- Position screen 22, plot setup 45, initial position fix 5,8; saving 9
- Power 11
- Product specifications 65
- Project 16
- Reference 11
- Routes 28; activating 31; active leg 29; deleting 35; creating 29; deactivating 31; reversing 31; Route Menu 28, viewing 35, editing 32, inserting a waypoint from the leg edit menu 33, replacing a waypoint 34, deleting a leg 34, viewing a leg 34, activating a leg 34
- Sat Status 46
- SETUP menu 39
- Signal reception 7
- Simulator 47
- Speed Units 41
- Sun/Moon 22
- Swivel Mount Bracket 52
- Time Display 41
- Troubleshooting 48
- Warning messages 50
- What is GPS? 66



*Magellan GPS 3000*

